

ENGLISH

Class - 2

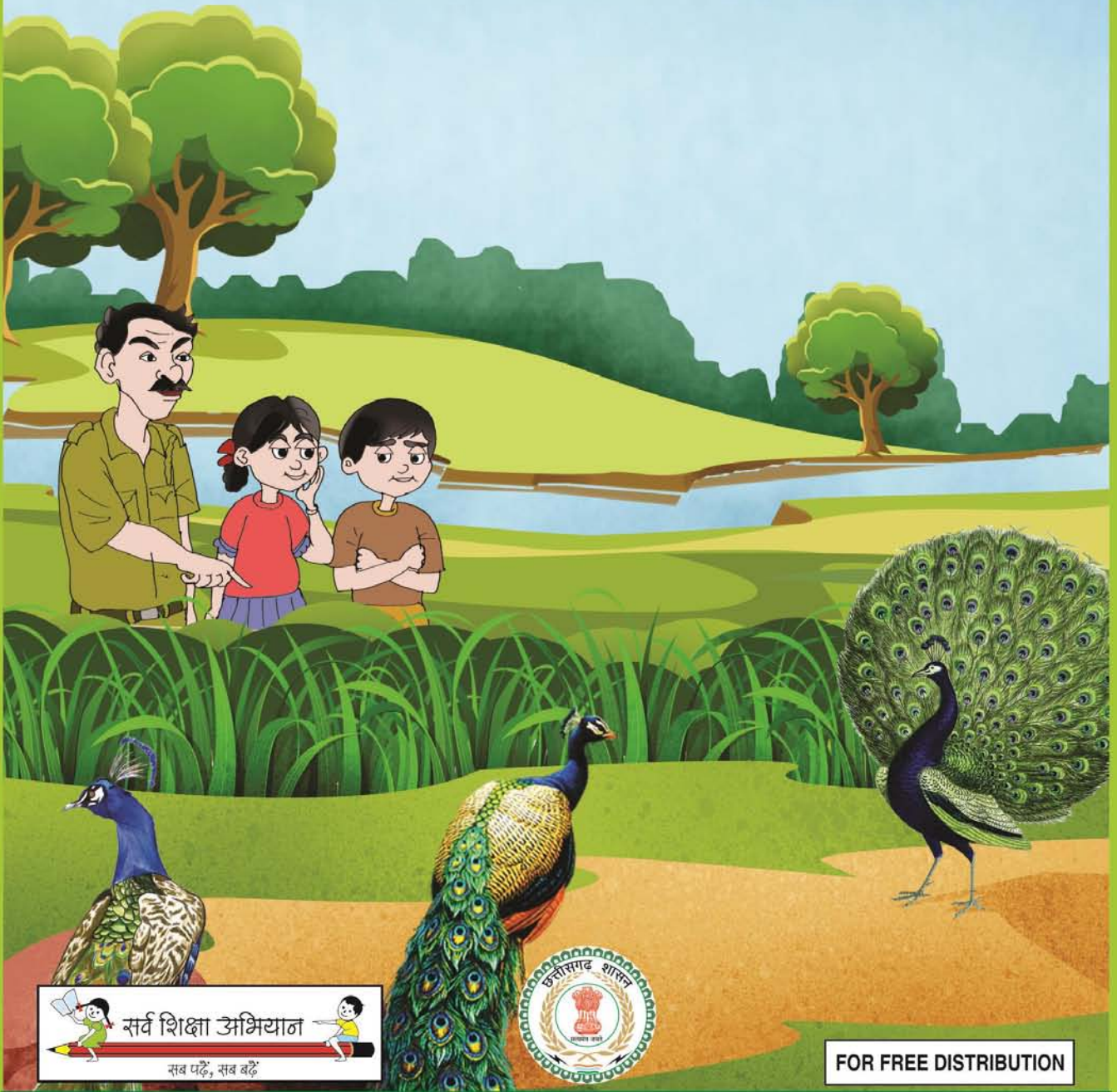

State Council of Educational Research and Training Chhattisgarh, Raipur



विद्यार्थियों को ऐसी तालीम दी जानी चाहिए जिससे वे संसार के महान धर्मों को आदर के साथ सीख सकें।
-महात्मा गांधी

राष्ट्रगीत वन्दे मातरम्

श्री बंकिमचंद्र चट्टोपाध्याय : आनंदमठ

वन्दे मातरम् ।
सुजलां सुफलां मलयजशीतलाम्,
शस्यश्यामलां मातरम् । वन्दे मातरम् ॥
शुभ्रज्योत्स्ना पुलकितयामिनीम्,
फुल्लकुसुमित द्रुमदलशोभिनीम्,
सुहासिनीं सुमधुरभाषिणीम्,
सुखदां वरदां मातरम् । वन्दे मातरम् ॥

ENGLISH

CLASS-2

सत्र 2019-20



DIKSHA एप कैसे डाउनलोड करें?

विकल्प 1: अपने मोबाइल ब्राउज़र पर diksha.gov.in/app टाइप करें।

विकल्प 2: Google Play Store में DIKSHA NCTE ढूँढ़ें एवं डाउनलोड बटन पर tap करें।



मोबाइल पर QR कोड का उपयोग कर डिजिटल विषय वस्तु कैसे प्राप्त करें

DIKSHA को लांच करें → App की समस्त अनुमति को स्वीकार करें → उपयोगकर्ता Profile का चयन करें



पाठ्यपुस्तक में QR Code को Scan करने के लिए मोबाइल में QR Code tap करें।



मोबाइल को QR Code पर केन्द्रित करें।



सफल Scan के पश्चात QR Code से लिंक की गई सूची उपलब्ध होगी

डेस्कटॉप पर QR Code का उपयोग कर सीजिटल विषय-वस्तु तक कैसे पहुँचें



1- QR Code के नीचे 6 अंकों का Alpha Numeric Code दिया गया है।



ब्राउज़र में diksha.gov.in/cg टाइप करें।



सर्च बार पर 6 डिजिट का QR CODE टाइप करें।



प्राप्त विषय-वस्तु की सूची से चाही गई विषय-वस्तु पर क्लिक करें।

राज्य शैक्षिक अनुसंधान और प्रशिक्षण पारिषद छत्तीसगढ़, रायपुर
निःशुल्क वितरण हेतु



PublicationYear 2019

© S.C.E.R.T.C.G., Raipur

Advisor

Dr. Ramakant Agnihotri, Deptt. of Linguistics, Delhi University

Convener

Dr. Vidyawati Chandrakar

Co-ordinator

Ms. S.N. Ali, S.C.E.R.T.C.G., Raipur

Writers

*Ms. S.N. Ali, Ms. J. Kurian, Ms. A. Verulkar, Shri M. Sudhish,
Ms. I. Sandhya Rani, Ms. Sisirkana Bhattacharya, Shri Ram Bandaru.*

Editors

*Ms. S.N. Ali, Ms. Sisirkana Bhattacharya, Ms. I. Sandhya Rani,
Ms. Jessy Kurian, Archana Verulkar, Valsa John,
Ali Mohammad, Kamlesh Kumar Sahu, Annapurna Patkar, Nandini Bajpai*

Illustrations

*Shri Khem Vaishnav, Shri Ritesh Dubey,
Shri Mona Sarkar, Shri Sanjay Sonay, Shri Sameer Shrivastava*

Cover Page

*Rekhranj Chouragadey
Hemant Joshi*

Assistance

Suresh Sahu, Mukund Sahu

Published by

Chhattisgarh Textbook Corporation, Raipur

Printed by

Preface

English Reader class VI is an innovative course for the students of class-6 of Chhattisgarh State. The book is an attempt to provide good and authentic material in English language with the focus on language learning for using the language in real life situations.

After 5 years of learning English, the book is an attempt to link the previous syllabus with the Communicative Functional Approach. At the upper Primary level, the focus is on all the skills of language learning. It is sincerely hoped that this book will help learners to enjoy language learning.

We would like to acknowledge the sincere help and guidance of Eklavaya, Vidya Bhawan Society & Digantar. For this book of English for Class VI, we are grateful to Prof. Ramakant Agnihotri & Shri A. Khanna, Delhi University for the orientation and interaction with the writers through workshops.

For giving permission to use copyright materials in the lesson, the Director, State Council of Educational Research and Training, Raipur C.G. wishes to thank the publisher Madhuban Educational Books, Mumbai, for *GOPAL BHAND AND MAHAGYANI*, the publisher Deshbandhu Publication Division, Raipur for *WOMEN FOR TREES*, Rupa & Company, New Delhi, for *JAGATU*, *THE GARDENER* and Orient Lognman for *THE HARE ON THE MOON*.

Thanks are also due to the publisher NCERT- Special Series for the Classes III-VIII for the material used in the poetry section—*IN THE HEART OF A SEED*, *WHO HAS SEEN THE WIND?*, *LITTLE DROPS OF WATER*, *RUNNING AND SHOUTING* and *PUPPY AND I*.

Every attempt has been made to get in touch with the concerned persons for the copyright for the lessons *A NICKEL'S WORTH OF FUN*—L. Patricia—“Focus” U.S.A.

We have adapted a translated version of the Russian folk tale *LEFT IN-CHARGE*. We are also thankful to the publisher Hamlyn Publishing Group for *JOLLY-KITTENS* from MY STORY BOOK. (GREAT BRITAIN)

ETB (Energized Text Book) is an innovative effort by the Department of school Education and State Council of Educational Research and Training Chhattisgarh for the capacity building of teachers and students by providing extra text book related content that can be accessed both online and off line(after downloading). The objective of ETBs is to offer extra topic related content (in interesting audio- video and animated formats), assessments and teacher reference material on the same platform.

The council welcomes suggestions from teachers, students, teacher trainers and parents for bringing to its notice any shortcomings or suggestions for improvement in the future editions of this book.

The Council would be grateful for bringing to its notice any shortcoming for improvement in future editions of this book. Any suggestions from teachers, parents, students, writers and publishers to improve the book, would be welcome. We wait eagerly for feedback from the users of the book.

Director

S.C.E.R.T.C.G., Raipur

शिक्षकों से ...

अंग्रेजी भाषा कक्षा-6 का यह संस्करण आपके हाथ में है। पुस्तक का प्रयास अंग्रेजी भाषा के शिक्षण को सरल-सुगम बनाने एवं बच्चों को अपने दैनिक जीवन में भाषा का प्रयोग करने योग्य बनाना है। इस हेतु भाषा के क्षेत्र की विभिन्न साहित्यिक विधाओं एवं रुचिकर सामग्री का चयन किया गया है। भाषा की विधाओं एवं व्याकरण सम्मत विषयों को क्रमबद्ध नहीं किया गया है, बल्कि उनका चयन दैनिक जीवन में उनके उपयोग पर निर्भर है। यह अपेक्षा की जाती है कि पाँच वर्षों तक (प्राथमरी स्तर तक) अंग्रेजी भाषा से परिचित होने के बाद बच्चे भाषा सीखने में रुचि लेंगे। पाठ्य पुस्तक में केवल 17 पाठों को रखा गया है। आरंभ के पाँच पाठों का उद्देश्य भाषा सीखने में बच्चों की रुचि एवं पढ़ने की आदत को विकसित करना है। ये पाठ बच्चों की दुनिया से जुड़े हुए रोचक पाठ्यसामग्री की सहायता से तैयार किये गये हैं जिनके माध्यम से नए शब्दों एवं वाक्यों से उनका परिचय हो सकेगा, आशा की जाती है कि इन पाठों को वे स्वयं ही पढ़ने को उत्सुक होंगे और अंग्रेजी भाषा का अनायास प्रयोग करना सीखेंगे।

कक्षा 6वीं के स्तर पर अंग्रेजी भाषा शिक्षण के समय शिक्षक निम्नांकित बिंदुओं को ध्यान में रखें -

- भाषा का आनंद उठाने में छात्रों की सहायता करना।
- बच्चों में शिक्षक के द्वारा एवं छात्रों द्वारा बोली गई भाषा को सुनकर समझने की दक्षता को विकसित करना।
- बच्चों में शिक्षक एवं अपने सहपाठियों को सुनकर सरल अंग्रेजी में अपने विचारों को अभिव्यक्त करने की क्षमता उत्पन्न करना। इस हेतु Role play समूहों में चर्चा एवं वाद विवाद जैसी क्रियाकलाप करवाना।
- बच्चों में पठन सामग्री को पढ़कर समझने की दक्षता विकसित करने के लिये अभ्यास प्रश्न करना।
- बच्चों को दैनिक जीवन में भाषा का उपयोग हेतु Notice board, समाचार पत्र, इंटरनेट, तालिकाएँ, चार्ट, मानचित्र, सार्वजनिक स्थानों में घोषण व निर्देश को समझने का अभ्यास कराना।
- बच्चों में भाषा की अभिव्यक्ति लिखित रूप में करने की दक्षता विकसित करना।
- भाषा की विभिन्न विधाओं से बच्चों को परिचित करवाना एवं उनका आनंद उठाने की क्षमता विकसित करना।
- बच्चों को भाषा के व्याकरण, शब्द संरचना, वाक्य विन्यास आदि से परिचित करवाना।

- भाषायी कौशलों के साथ-साथ Study Skill एवं त्ममितमदबम Reference Skill को विकसित करना। किसी भी प्रकार की दृश्य सामग्री को पढ़कर समझना एवं आवश्यक जानकारी प्राप्त करने की क्षमता विकसित करना।
- 'Outcomes for class-6' में दिए गए समस्त उद्देश्यों को पूरा करना।
- इन उद्देश्यों की पूर्ति के लिये निम्नांकित बिंदुओं को पाठ्य पुस्तक में स्थान दिया गया है -कक्षा में छात्र केन्द्रित शिक्षण का वातावरण निर्मित करें।
- शिक्षक बच्चों को सीखने में मदद करें।
- पाठ्य पुस्तक के पीछे दी गई Glossary का उपयोग शब्दों के अर्थ एवं उच्चारण जानने के लिये करें।
- पाठ्य पुस्तक के अंत में Lesson wise Details को पाठ पढ़ाने के पूर्व अवश्य देख लें।
- पुस्तक के Appendix-1 में Listening Passages दिये गये हैं जिनका उपयोग Listening Exercises करवाने में करना है। कक्षा में ये अभ्यास करवाने के पूर्व शिक्षकों को स्वयं एक-दो बार जोर से पढ़ने का अभ्यास अवश्य कर लेना चाहिए।
- Appendix-2 में About the Lesson (हिन्दी/अंग्रेजी) के अन्तर्गत प्रत्येक पाठ की जानकारी उपलब्ध करवाई गई है। पाठ पढ़ाने के पूर्व एक बार पाठ के संदर्भ की जानकारी अवश्य ले लें।
- प्रत्येक पाठ के पीछे दिये गये अभ्यास कार्य कक्षा-गत क्रियाओं पर आधारित है अतएव प्रत्येक अभ्यास में दिये गये निर्देशों का पालन अवश्य करें।
- कुछ पाठों के पीछे दिये गये Project के अन्तर्गत Paper folding activity के माध्यम से बच्चों को किसी Art की जानकारी दी गई है। Project का उद्देश्य अंग्रेजी भाषा में दिये गये Instructions को समझकर कार्य करवाना है, जिससे छात्र कुछ मजेदार आकृतियाँ बना सकेंगे, उनका उपयोग कर सकेंगे तथा उन्हें अपने दैनिक जीवन में भाषा को सीखने तथा उसका प्रयोग करने के लिये प्रेरणा मिल सकेगी।

संचालक

राज्य शैक्षिक अनुसंधान और प्रशिक्षण परिषद्
छत्तीसगढ़, रायपुर

Outcomes for Class-6

The learner-

- ❑ participates in activities in English like role play, group discussion, debate, etc.
- ❑ recites and shares poems, songs, jokes, riddles, tongue twisters, etc.
- ❑ responds to oral messages, telephonic communication in English and communicates them in English or home language.
- ❑ responds to announcements and instructions made in class, school assembly, railway station and in other public places reads a variety of texts in English / Braille and identifies main ideas, characters, sequence of ideas and events and relates with his/her personal experiences.
- ❑ reads to seek information from notice board, newspaper, Internet, tables, charts, diagrams and maps etc.
- ❑ responds to a variety of questions on familiar and unfamiliar texts verbally and in writing.
- ❑ uses synonyms, antonyms appropriately deduces word meanings from clues in context while reading a variety of texts.
- ❑ writes words / phrases / simple sentences and short paragraphs as dictated by the teacher
- ❑ uses meaningful sentences to describe / narrate factual / imaginary situations in speech and writing
- ❑ refers to dictionary to check meaning and spelling, and to suggested websites for information.
- ❑ writes grammatically correct sentences for a variety of situations, using noun, pronoun, verb, adverb, determiners, etc.
- ❑ drafts, revises and writes short paragraphs based on verbal, print and visual clues.
- ❑ writes coherently with focus on appropriate beginning, middle and end in English / Braille.
- ❑ writes messages, invitations, short paragraphs and letters (formal and informal) and with a sense of audience.
- ❑ visits a language laboratory.
- ❑ writes a book review.

Salient Features of the Book

The book aims to:

1. help the learners to communicate and express themselves in English in day to day life.
2. develop in them the four essential skills of the language *Listening, Speaking, Reading* and *Writing*.
3. promote interest in learning the language.
4. develop 21st century skills i.e. collaboration, creativity, critical thinking and problem solving

To meet out the aims of the language learning, the book has the following features:

- Learning with fun
- Learner—centered approach
- Task /activity based learning
- Focus on developing language skills
- Challenging themes and exercises
- Within learners experience.
- Variety of the text forms : picture story, comic—strip, letter, folk story, news item, informative text etc.
- Authentic material—taken from classics, newspapers, magazines etc.
- Illustrations to help better understanding of the text
- Enough space to develop study skills
- Glossary—(English to Hindi)
- Language Syllabus

The book has its layout in the following setup:

Part A—

- Lessons/poems (content)
- Word—Meanings
- Reading Comprehension
- Vocabulary
- Grammar
- Writing
- Activity (A) Listening (B) Speaking
- Project.

Part B—

1. Appendix - 1. Listening passages for listening exercises are given in the appendix.
2. Appendix-2. About the lessons.
3. Appendix-3. Glossary
4. Syllabus-lesson wise.

CONTENTS

S.No.	Lessons	Page No.
1.	Conversation	1-2
2.	The Sun Goes on a Holiday	3-7
3.	Pretending	8-9
4.	A Masai Home	10-13
5.	Alice in Wonderland	14-20
6.	In the Heart of a Seed	21-22
7.	Jolly Kittens	23-33
8.	The Hare on the Moon	34-41
9.	Running and Shouting	43-46
10.	Jagatu-the Gardener	47-55
11.	Left in Charge	56-64
12.	Who has Seen the Wind?	65-67
13.	Gopal Bhand and Mahagyani	68-74
14.	Puppy and I	75-80
15.	A Nickel's Worth of Fun	81-88
16.	Women for Trees	89-96
17.	Little Drops of Water	97-99
	Appendix-1	100-104
	Appendix-2	105-109
	Appendix-3	110-116
	Syllabus	



ABOUT ME



Note for the Teacher :

- 1 . इस चित्र के माध्यम से बच्चों से उनके परिवार के बारे में चर्चा करें।
- 2 . बच्चों को अपना परिचय देने का अभ्यास करवाएँ। (मौखिक एवं लिखित)

Ex.- My name is _____.

I am ----- years old.

My father's name is _____.

My mother's name is _____.



GOOD MORNING SONG

“Good morning Good morning,
How are you?”

“Good morning, Good morning,
Fine, thank you!”

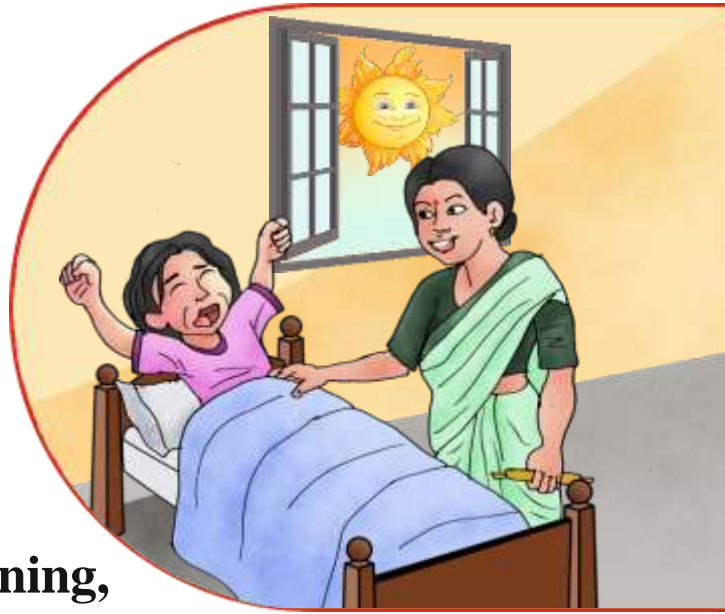

“Good morning, Good morning,
How do you do?”

“Good morning, Good morning,
How do you do?”

Repeat after your teacher :

good, should, would	thank, bank, tank
fine, mine, shine	how, cow, now

Note for the Teacher : कविता को Good afternoon, Good evening के साथ दोहराएँ ।



SEARCH ENGINE

Trace the route from A to Z and colour the circle in which the first letter of your name is written.

A से Z का रास्ता ढूँढो और अपने नाम के पहले अक्षर के गोले में रंग भरो-

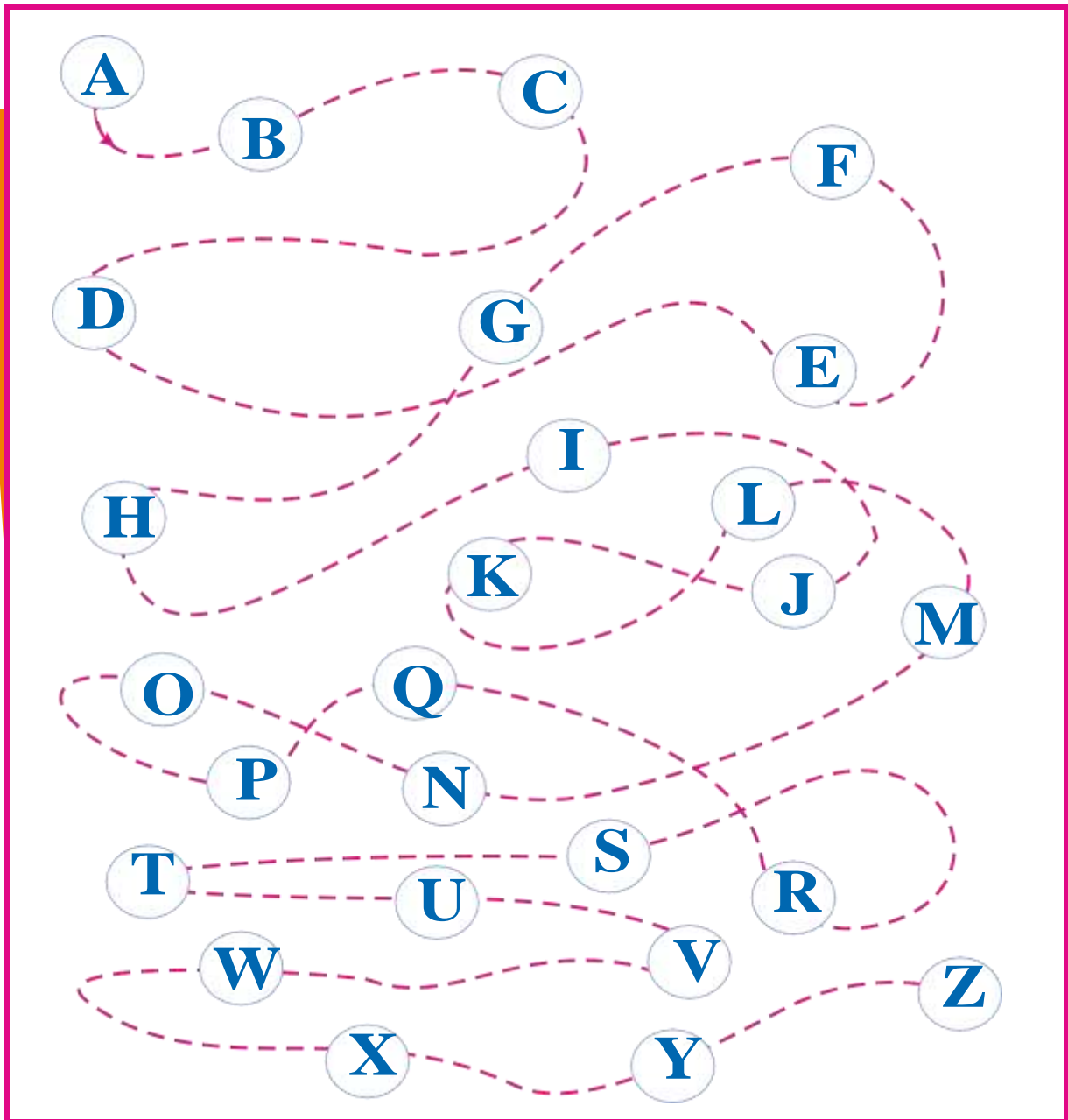



GOD IS GREAT

God is great, God is good,
Thank you God for the food,
God teach me day by day,
What I have to do and say,
God bless us, God bless all.



Repeat after your teacher:

good	-	should, could
thank	-	bank, tank
teach	-	reach, beach
food	-	mood, rude
say	-	day, hay
all	-	ball, tall

Note for the Teacher :

- प्रार्थना के उद्देश्य के बारे में चर्चा करें।
- प्रार्थना का लय के साथ अभ्यास करवाएँ।
- 'Thank you' का अर्थ एवं उसका प्रयोग कहाँ किया जाना है इसकी जानकारी बच्चों को दें।



Match the capital letters to the small letters.

जोड़ी बनाओ

1

2

A B C
D E F
G H I
J K L
M N O
P Q R
S T U
V W X
Y Z

o y p
h e l
g d i
k j f
w q a
c n r
s z u
b v x
m t



REFERENCE TIME -1

L

l



a leaf



a lotus



a lion



a lizard

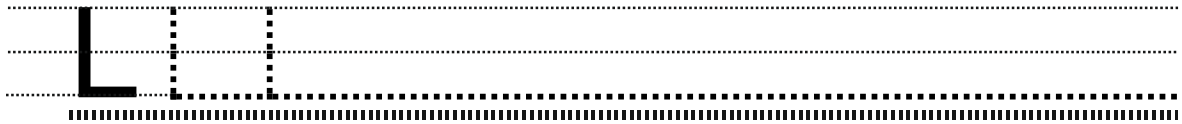

Note for the Teacher : 'L' से प्रारंभ होने वाले अन्य शब्दों के बारे में चर्चा करें एवं उनके चित्र पोर्टफोलियो में चिपकाने को कहें।

TRACING - 6

Tracing practice for the letter 'L' on a four-line grid. The first row shows a solid 'L' followed by two dashed 'L's. The second row shows a solid 'L' followed by two dashed 'L's. The third row shows a solid 'L' followed by two dashed 'L's. The fourth row shows a solid 'L' followed by two dashed 'L's. The fifth row shows a solid vertical line followed by two dashed vertical lines. The sixth row shows a solid vertical line followed by two dashed vertical lines. The seventh row shows a solid vertical line followed by two dashed vertical lines. The eighth row shows a solid vertical line followed by two dashed vertical lines. To the right of the first row are two line drawings of apples. To the right of the seventh row are three line drawings of leaves.

Note for the Teacher : चित्रों में रंग भरवाएँ एवं उनके अंग्रेजी नाम का अभ्यास करवाएँ



REFERENCE TIME -2

I

i



insects

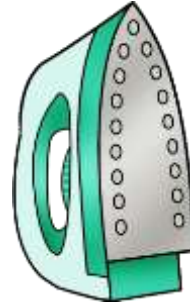

an iron



an infant



an inkpot

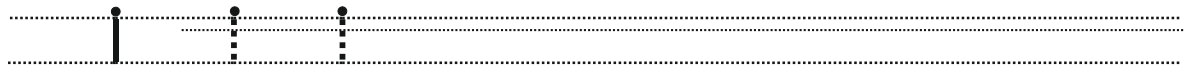
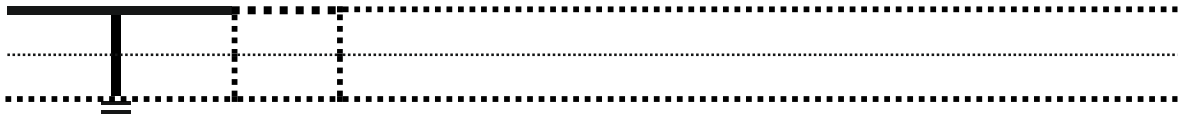

Note for the Teacher : 'I' से प्रारंभ होने वाले अन्य शब्दों के बारे में चर्चा करें एवं उनके चित्र पोर्टफोलियो में चिपकाने को कहें।

TRACING - 7

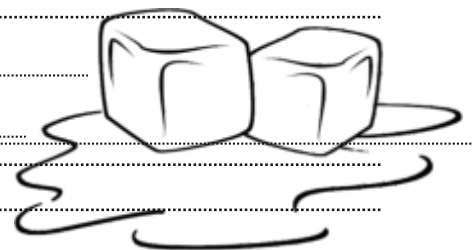
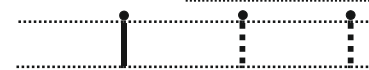
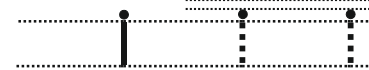
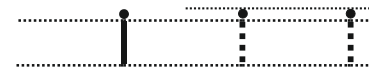
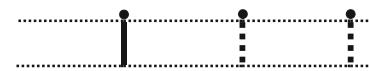
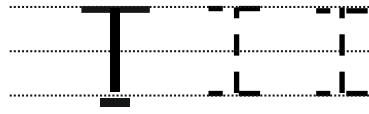
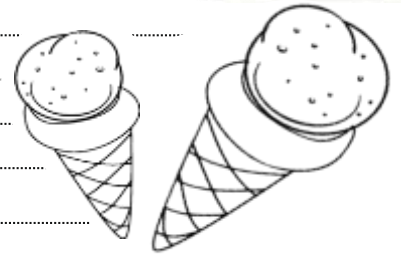
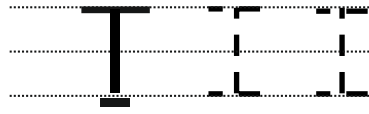

Note for the Teacher : चित्रों में रंग भरवाएँ एवं उनके अंग्रेजी नाम का अभ्यास करवाएँ



REFERENCE TIME -3

T
t



a tomato



a tree



a tortoise

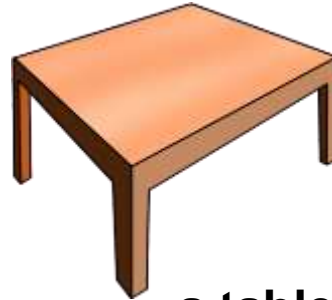

a table

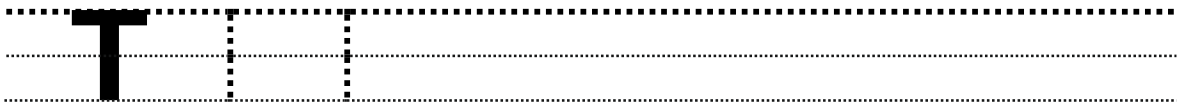

Note for the Teacher : 'T' से प्रारंभ होने वाले अन्य शब्दों के बारे में चर्चा करें एवं उनके चित्र पोर्टफोलियो में चिपकाने को कहें।

TRACING - 8

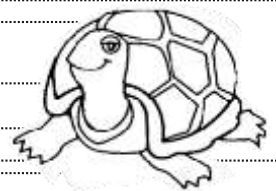
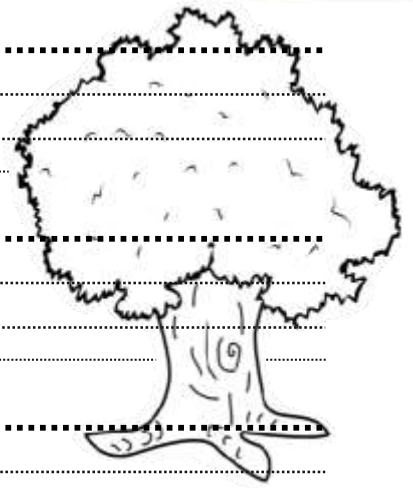
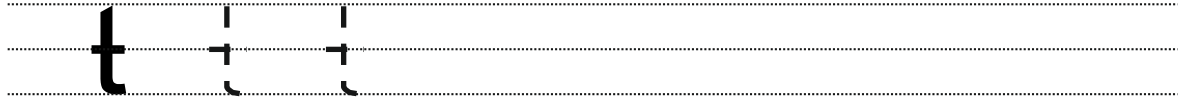
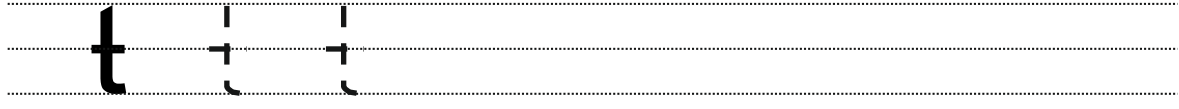
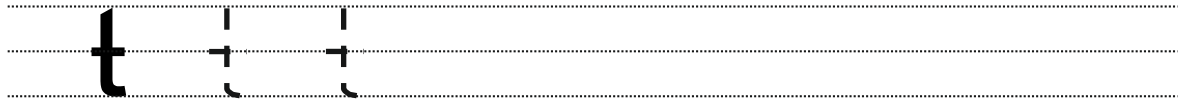
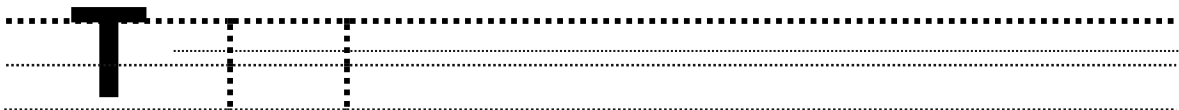
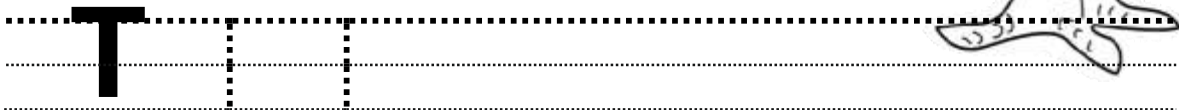
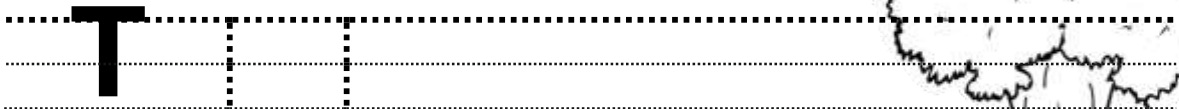
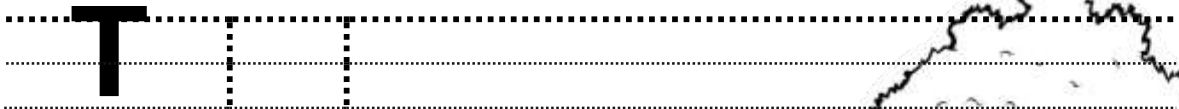

Note for the Teacher : चित्रों में रंग भरवाएँ एवं उनके अंग्रेजी नाम का अभ्यास करवाएँ



REFERENCE TIME - 4

E

e



an eye

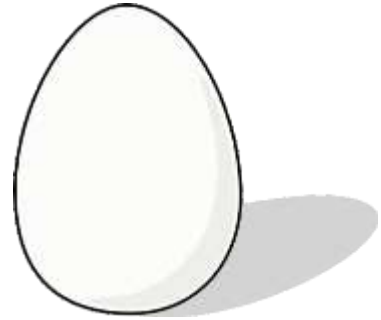

an egg



an ear

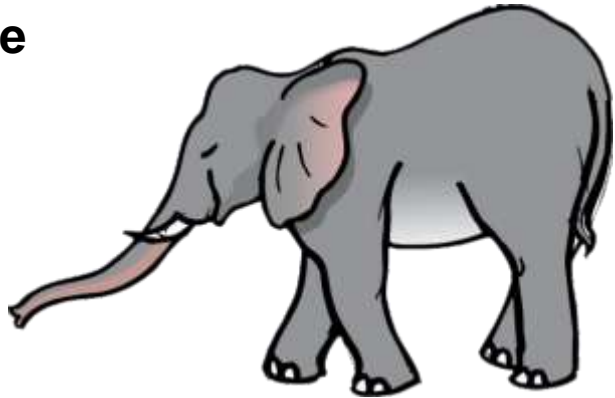

an elephant

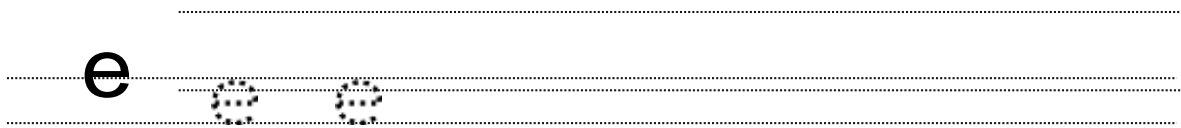
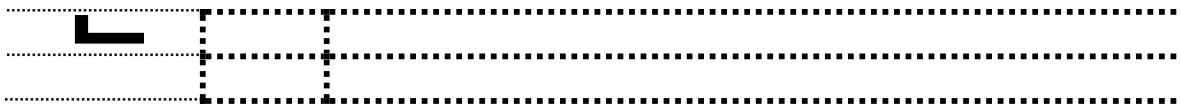

Note for the Teacher : 'E' से प्रारंभ होने वाले अन्य शब्दों के बारे में चर्चा करें एवं उनके चित्र पोर्टफोलियो में चिपकाने को कहें।

TRACING - 9

E

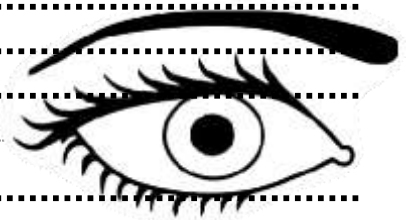

E



E

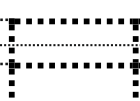

E

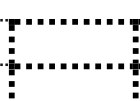

e

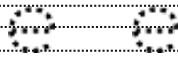

e



e

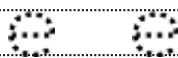

e

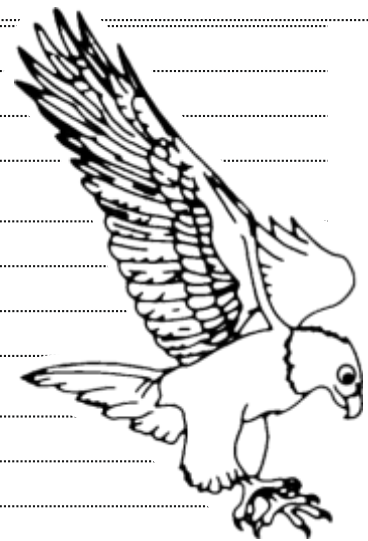
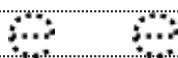

Note for the Teacher : चित्रों में रंग भरवाएँ एवं उनके अंग्रेजी नाम का अभ्यास करवाएँ



REFERENCE TIME - 5

F

f



a fish



a frog



fruits



a fox

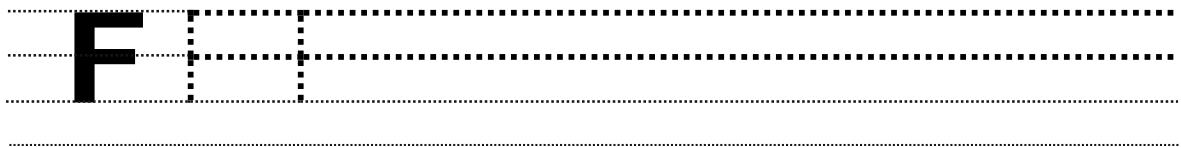

Note for the Teacher : 'F' से प्रारंभ होने वाले अन्य शब्दों के बारे में चर्चा करें एवं उनके चित्र पोर्टफोलियो में चिपकाने को कहें।

TRACING - 10

F F

F F

F F

F F

f f f

f f f

f f f

f f f

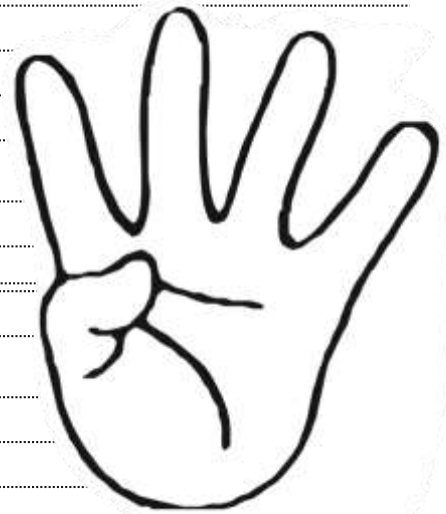
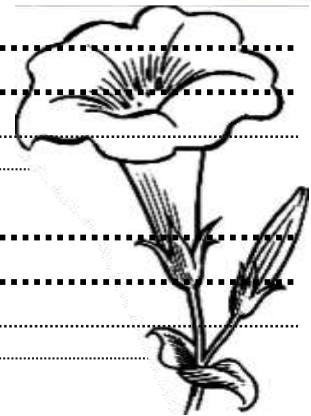

Note for the Teacher : चित्रों में रंग भरवाएँ एवं उनके अंग्रेजी नाम का अभ्यास करवाएँ



REFERENCE TIME -6

H

h



a house



a hen



a hammer

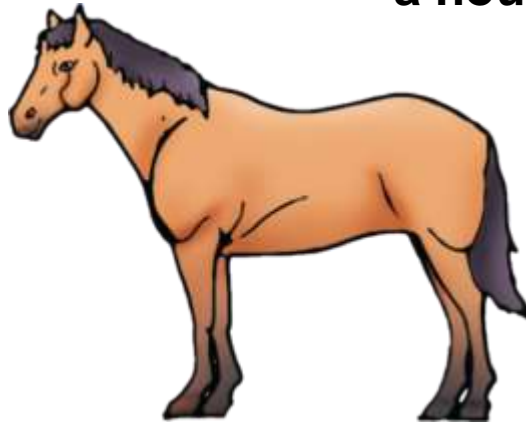

a horse



Note for the Teacher : 'H' से प्रारंभ होने वाले अन्य शब्दों के बारे में चर्चा करें एवं उनके चित्र पोर्टफोलियो में चिपकाने को कहें।

TRACING - 1

H H H

H H H

H H H

H H H

h h h

h h h

h h h

h h h

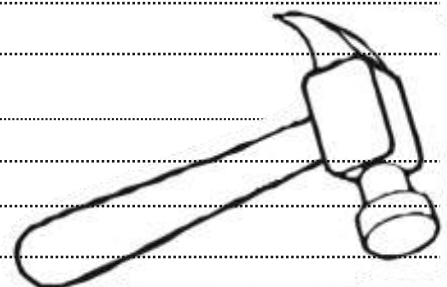
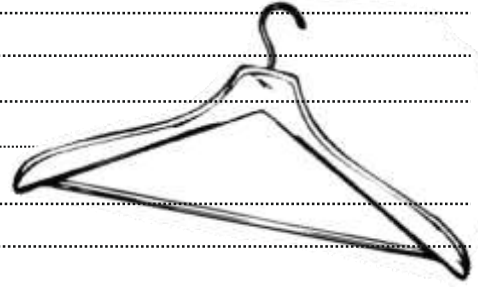

Note for the Teacher : चित्रों में रंग भरवाएँ एवं उनके अंग्रेजी नाम का अभ्यास करवाएँ

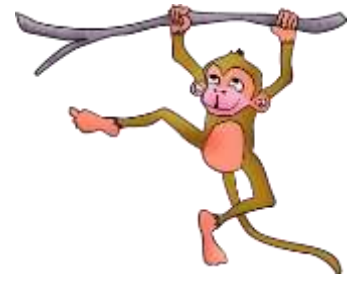

BIG AND SMALL



An elephant is big.

A monkey is small.

A snake is thin.

A giraffe is tall.



Repeat after your teacher:

big - dig, pig, wig

small - tall, ball, call

thin - bin, tin, pin

Note for the Teacher :

- 1 कविता का सही लय के साथ अभ्यास करवाएँ।
- 2 Big, small, thin , एवं tall के बारे में बच्चों से चर्चा करें।
- 3 कविता का action के साथ अभ्यास करवाएँ।



WORKSHEET - 1

1. Repeat the word. Circle 'i' or 'I' in the words.
शब्द दोहराओ। 'i', एवं 'I' को गोला लगाओ।



infant



Ice-cream



inkpot

2. Name the pictures and fill the first letter

चित्रों के नाम बताओ एवं खाली स्थान में पहला अक्षर भरो।



___op



___an

10

___en



___an



___ock

3. Write the corresponding small/capital letters in the boxes.
दिए गए बॉक्स में अक्षर लिखो। (small/capital)

E

L

i

h

t

F



REFERENCE TIME - 7

Z
z



a zebra

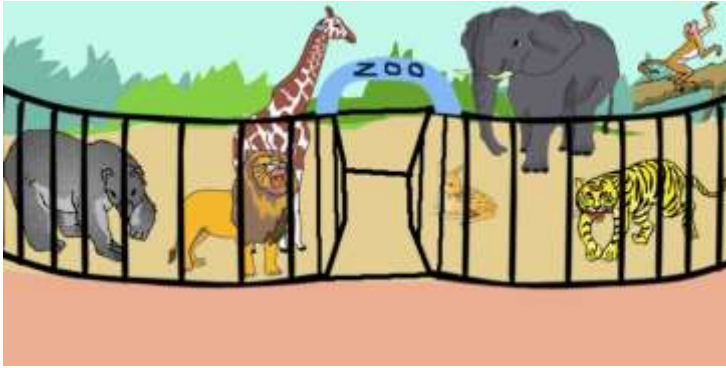

a zoo

0

a zero

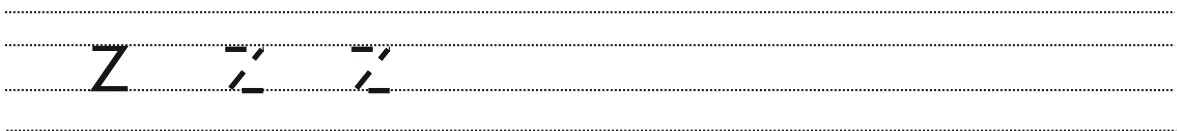
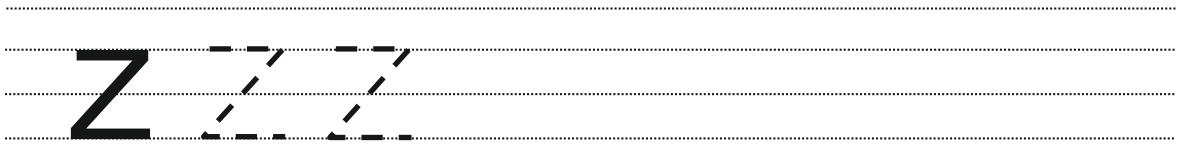

Note for the Teacher : 'Z' से प्रारंभ होने वाले अन्य शब्दों के बारे में चर्चा करें एवं उनके चित्र पोर्टफोलियो में चिपकाने को कहें।

TRACING - 12

Z Z Z

Z Z Z

Z Z Z

Z

Z Z Z

Z Z Z

Z Z

Note for the Teacher : चित्र में रंग भरवाएँ एवं उसके अंग्रेजी नाम का अभ्यास करवाएँ

Z Z Z



REFERENCE TIME - 8

A

a

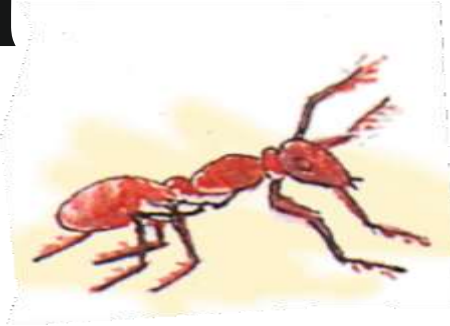

an ant



an almirah



an axe



an apple

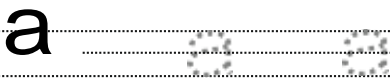
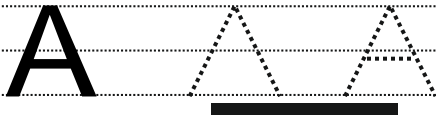

Note for the Teacher : 'A' से प्रारंभ होने वाले अन्य शब्दों के बारे में चर्चा करें एवं उनके चित्र पोर्टफोलियो में चिपकाने को कहें।

TRACING - 13

A A A

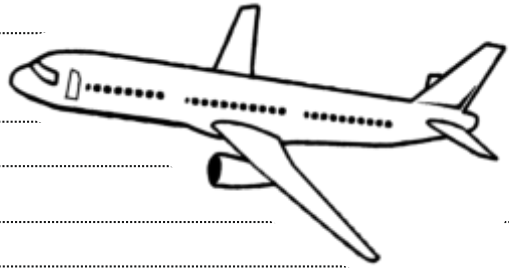

A A A

A A A

A A A

a a a

a a a

a a a

a a a



Note for the Teacher : चित्रों में रंग भरवाएँ एवं उनके अंग्रेजी नाम का अभ्यास करवाएँ



REFERENCE TIME - 9

V

v



a vase



a violin

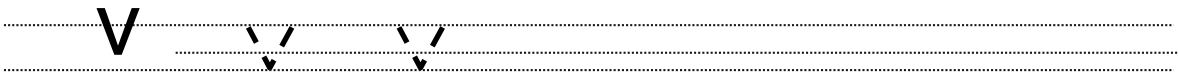
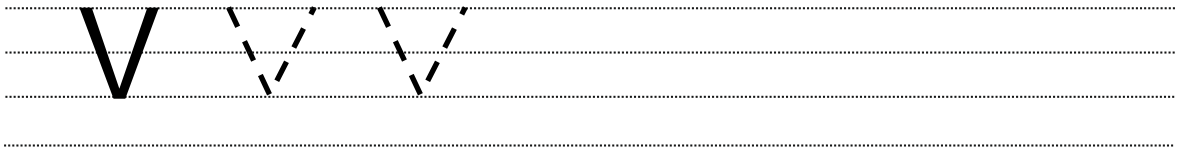

Note for the Teacher : 'V' से प्रारंभ होने वाले अन्य शब्दों के बारे में चर्चा करें एवं उनके चित्र पोर्टफोलियो में चिपकाने को कहें।

TRACING - 14

V V V

V V V

V V V

V V V

V V V

V V V

V V V

V V V

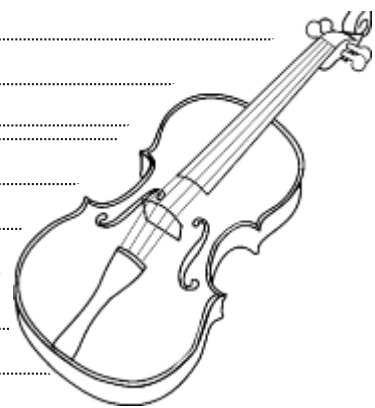

Note for the Teacher : चित्रों में रंग भरवाएँ एवं उनके अंग्रेजी नाम का अभ्यास करवाएँ



REFERENCE TIME - 10

N

n



a nurse

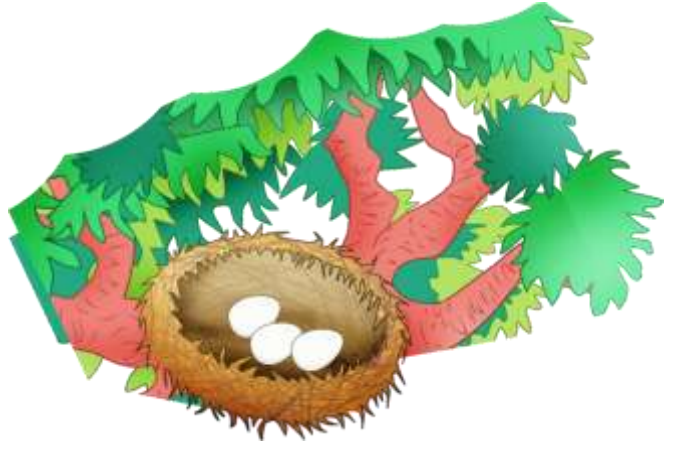

a nest



a nose



a nib



Note for the Teacher : 'N' से प्रारंभ होने वाले अन्य शब्दों के बारे में चर्चा करें एवं उनके चित्र पोर्टफोलियो में चिपकाने को कहें।

TRACING - 15

N N N N

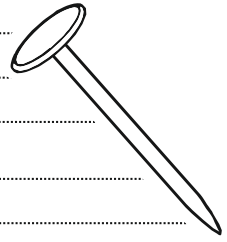

N N N N

N N N N

N N N N

n n n n

n n n n

n n n n

n n n n

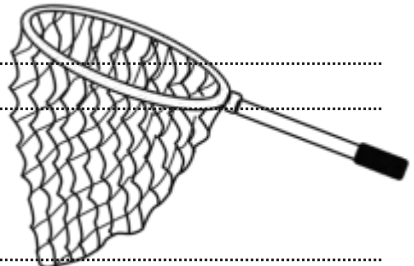

Note for the Teacher : चित्रों में रंग भरवाएँ एवं उनके अंग्रेजी नाम का अभ्यास करवाएँ



WORKSHEET - 2

Recognize the picture and tick(✓) the correct spelling (shape).

चित्र पहचानो एवं सही शब्द पर (✓) का चिन्ह लगाओ।



Zebra ✓

Zabre

Bezra

Zbrea



Apple

Appel

Apelp

Alpep



Vset

Setv

Tesv

Vest



Nste

Nset

Nest

Ntse



Bin

Nib

Nbi

BNi



Nav

Van

Nva

Vna

0

Zeor

Zreo

Zero

Orez



Almhiar

Ahmiral

Amiralh

Almirah



WHAT DO YOU EAT !

Oh! Mr. Elephant, oh! Mr. Elephant,
What do you eat ?
It's sugar cane, It's sugar cane
That I love to eat.

Oh! Mr. Rabbit, oh! Mr. Rabbit,
What do you eat?
It's carrot, It's carrot.
That I love to eat.

Oh! Mr. Cat, oh! Mr. Cat,
What do you drink ?
It's milk, It's milk
That I love to drink.



eat



drink



Repeat after your teacher:

Mr. (mister) - sister
eat - beat
what - cot
love - above

drink - think
milk - silk
rabbit - habit

Note for the Teacher :

- 1 . सही लय के साथ कविता का अभ्यास करवाएँ।
- 2 . जानवरों एवं उनके खान-पान के बारे में चर्चा करें।
- 3 . बच्चों को कविता आगे बढ़ाने में मदद करें।
- 4 . खाली स्थान भरवाएँ।

Oh! Mr. _____ oh! Mr. _____
Its -----Its -----
That I love to eat/drink.



REFERENCE TIME -11

X

x



X- mas



an X-mas tree



a xerox machine

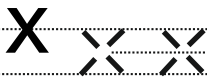
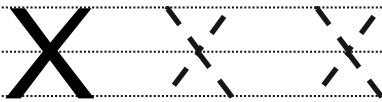

Note for the Teacher : 'X' से प्रारंभ होने वाले अन्य शब्दों के बारे में चर्चा करें एवं उनके चित्र पोर्टफोलियो में चिपकाने को कहें।

TRACING - 16

X X X

X X X

X X X

X X X

X X X

X X X

X X X

X X X

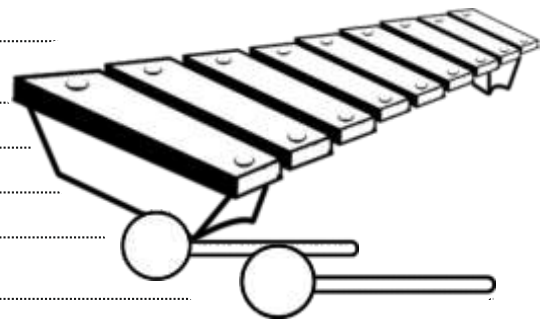

Note for the Teacher : चित्रों में रंग भरवाएँ एवं उनके अंग्रेजी नाम का अभ्यास करवाएँ



REFERENCE TIME -12

Y

y



a yak



a yacht



a yarn

Y Y Y

y y y

Note for the Teacher : 'Y' से प्रारंभ होने वाले अन्य शब्दों के बारे में चर्चा करें एवं उनके चित्र पोर्टफोलियो में चिपकाने को कहें।

TRACING - 17

Y Y Y

Y Y Y

Y Y Y

Y Y Y

y y y

y y y

y y y

y y y

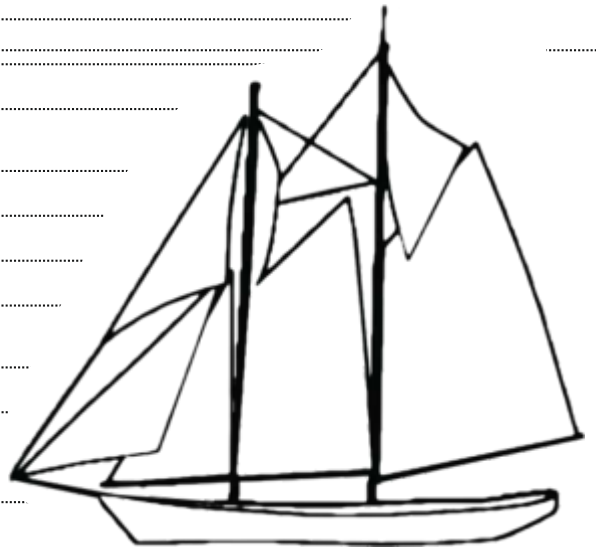

Note for the Teacher : चित्रों में रंग भरवाएँ एवं उनके अंग्रेजी नाम का अभ्यास करवाएँ



REFERENCE TIME -13

K

k



a kitchen



a kitten



a key



a kite

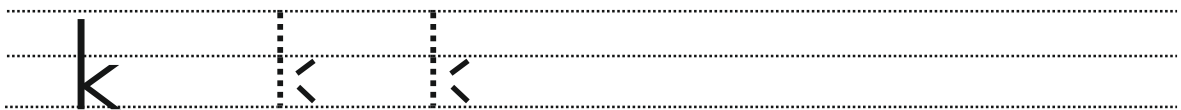

Note for the Teacher : 'K' से प्रारंभ होने वाले अन्य शब्दों के बारे में चर्चा करें एवं उनके चित्र पोर्टफोलियो में चिपकाने को कहें।

TRACING - 18

K K K

K K K

K K K

K K K

k k k

k k k

k k k

k k k



Note for the Teacher : चित्रों में रंग भरवाएँ एवं उनके अंग्रेजी नाम का अभ्यास करवाएँ



REFERENCE TIME -14

M

m



a monkey



a mango



a match box



a milkman

M M M

m m m

Note for the Teacher : 'M' से प्रारंभ होने वाले अन्य शब्दों के बारे में चर्चा करें एवं उनके चित्र पोर्टफोलियो में चिपकाने को कहें।

TRACING - 19

M M M

M M M

M M M

M M M

m m m

m m m

m m m

m m m

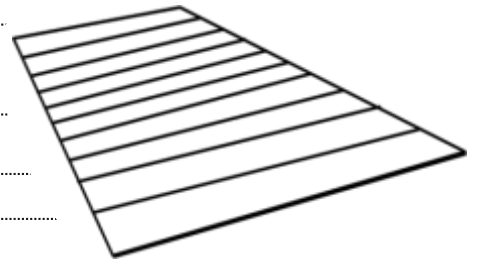
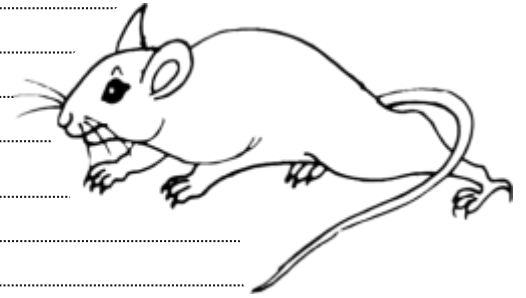

Note for the Teacher : चित्रों में रंग भरवाएँ एवं उनके अंग्रेजी नाम का अभ्यास करवाएँ



REFERENCE TIME -15

W

w



a wood-pecker



a watch



a watermelon



a wolf

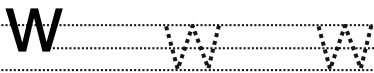
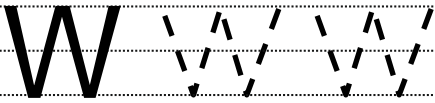

Note for the Teacher : 'W' से प्रारंभ होने वाले अन्य शब्दों के बारे में चर्चा करें एवं उनके चित्र पोर्टफोलियो में चिपकाने को कहें।

TRACING - 20

W W W

W W W

W W W

W W W

W W W

W W W

W W W

W W W

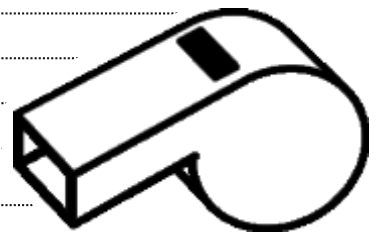
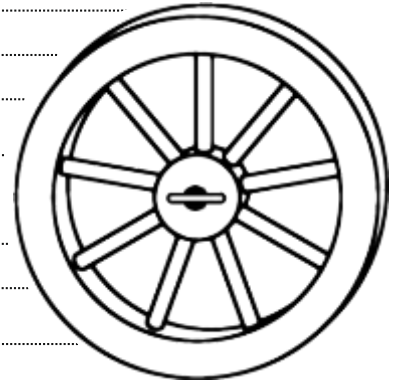

Note for the Teacher : चित्रों में रंग भरवाएँ एवं उनके अंग्रेजी नाम का अभ्यास करवाएँ



WORKSHEET - 3

There is a letter written on each bogie of the train. Recognise the pictures and take them to the bogie on which their first letter is written.

रेलगाड़ी के डिब्बों पर एक-एक अक्षर लिखा हुआ है। चित्रों को पहचानो एवं उनके प्रारंभिक अक्षर के अनुसार उन्हें उनके डिब्बों तक पहुंचाओ।



TRACING - 21

See the picture and fill the blank .

चित्र को देखो एवं खाली स्थान में अक्षर भरो।

1. He has a an.

He has a an

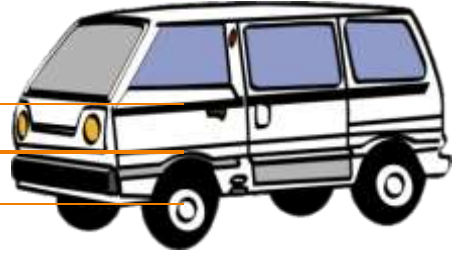

2. I have a ite.

I have a ite



3. We live in a ree .

We live in a ree



4. The an is thin .

The an is thin

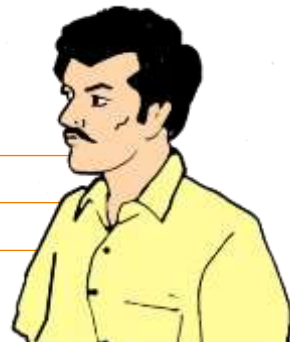



REFERENCE TIME -16

C

C



a chair



a cat



a coconut

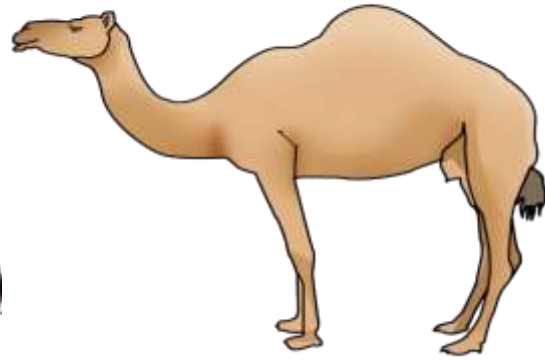

a camel

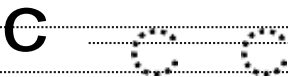
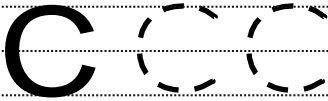

Note for the Teacher : 'C' से प्रारंभ होने वाले अन्य शब्दों के बारे में चर्चा करें एवं उनके चित्र पोर्टफोलियो में चिपकाने को कहें।

TRACING - 22

C C C

C C C

C C C

C C C

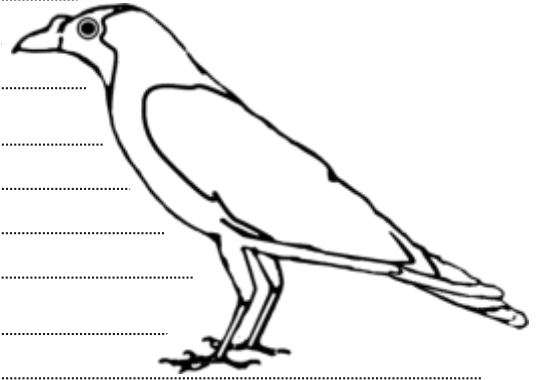

c c c

c c c

c c c

c c c

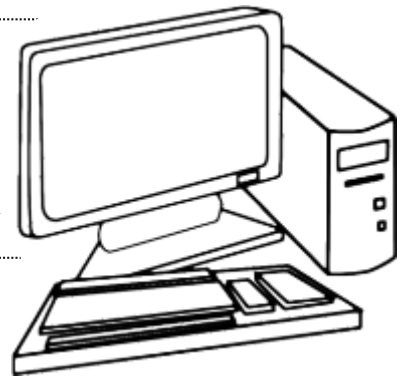

Note for the Teacher : चित्रों में रंग भरवाएँ एवं उनके अंग्रेजी नाम का अभ्यास करवाएँ



REFERENCE TIME -17

O

o



an orange



an oldman



an owl

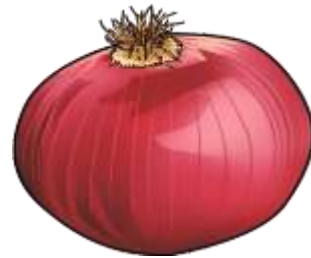

an onion

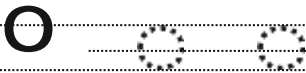
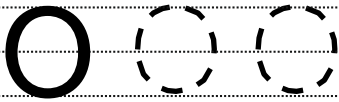

Note for the Teacher : 'O' से प्रारंभ होने वाले अन्य शब्दों के बारे में चर्चा करें एवं उनके चित्र पोर्टफोलियो में चिपकाने को कहें।

TRACING - 23

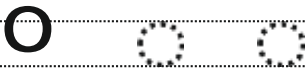
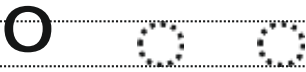
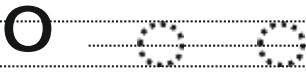
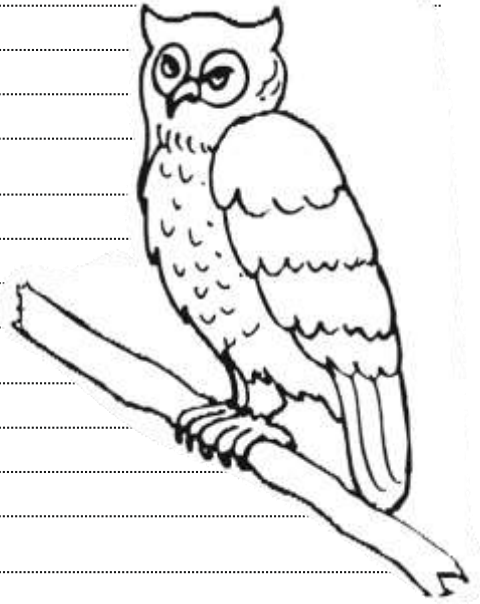
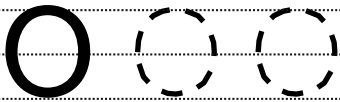
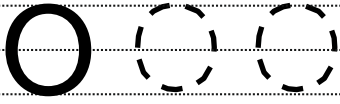

Note for the Teacher : चित्रों में रंग भरवाएँ एवं उनके अंग्रेजी नाम का अभ्यास करवाएँ



REFERENCE TIME -18

Q

q



a queen



a quarter



a queue



a question
mark

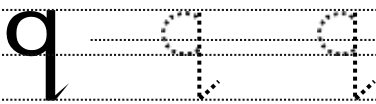
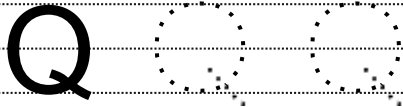

Note for the Teacher : 'Q' से प्रारंभ होने वाले अन्य शब्दों के बारे में चर्चा करें एवं उनके चित्र पोर्टफोलियो में चिपकाने को कहें।

TRACING - 24

Q Q Q

Q Q Q

Q Q Q

q q q

q q q

q q q

q q q

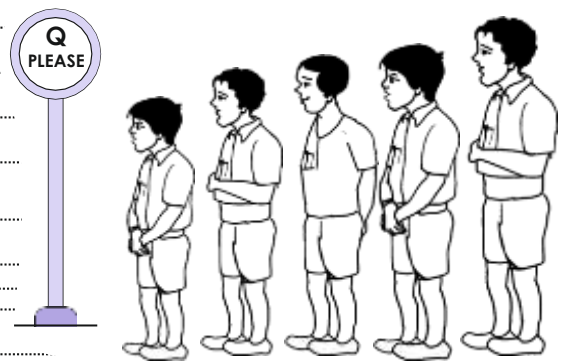

Note for the Teacher : चित्रों में रंग भरवाएँ एवं उनके अंग्रेजी नाम का अभ्यास करवाएँ



REFERENCE TIME -19

D

d



a drum



a doctor

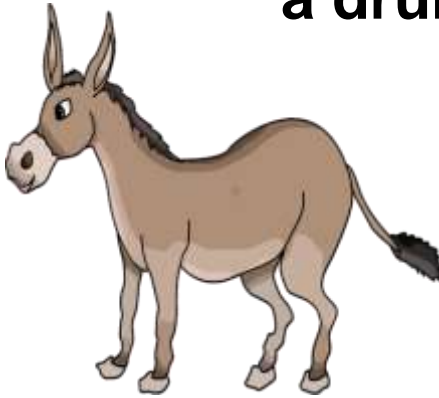

a donkey



a dog

D D D

d d d

Note for the Teacher : 'D' से प्रारंभ होने वाले अन्य शब्दों के बारे में चर्चा करें एवं उनके चित्र पोर्टफोलियो में चिपकाने को कहें।

TRACING - 25

D D D

D D D

D D D

D D D

d d d

d d d

d d d

d d d

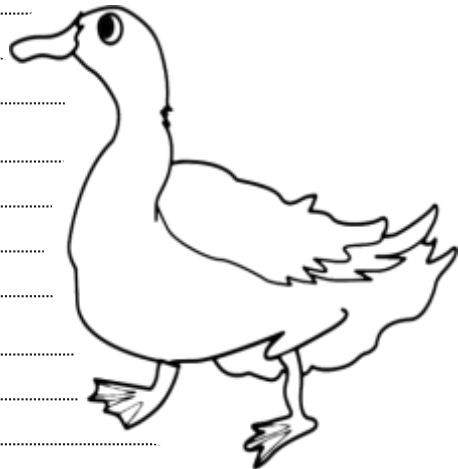
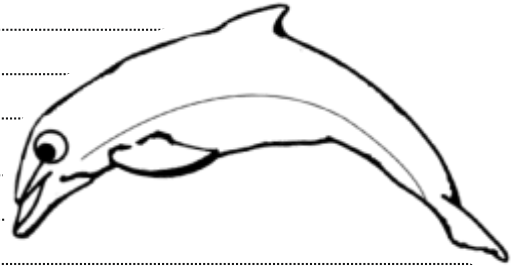

Note for the Teacher : चित्रों में रंग भरवाएँ एवं उनके अंग्रेजी नाम का अभ्यास करवाएँ



REFERENCE TIME - 20

B

b

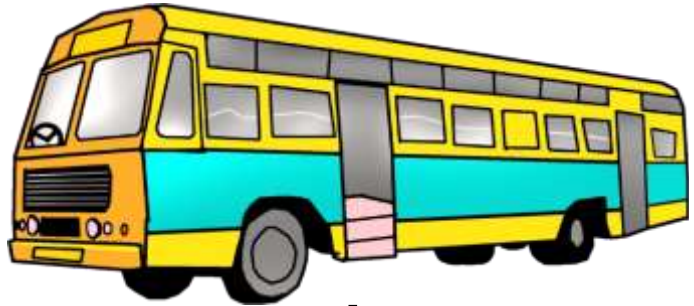

a bus



a bat



a bird



a boy



a banana

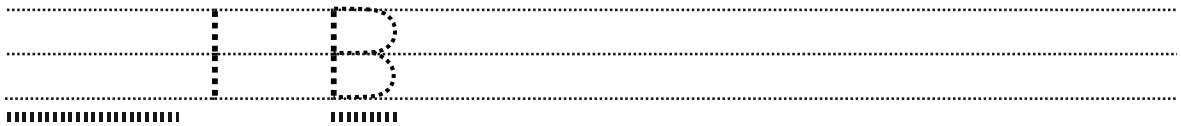

Note for the Teacher : 'B' से प्रारंभ होने वाले अन्य शब्दों के बारे में चर्चा करें एवं उनके चित्र पोर्टफोलियो में चिपकाने को कहें।

TRACING - 26

B B B

B B B

B B B

B B B

b b b

b b b

b b b

b b b

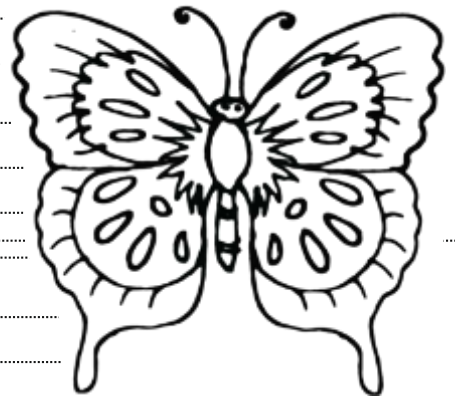
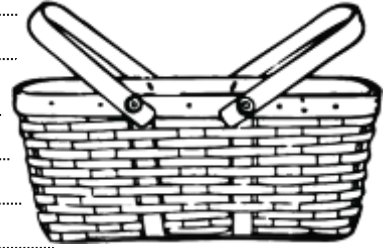

Note for the Teacher : चित्रों में रंग भरवाएँ एवं उनके अंग्रेजी नाम का अभ्यास करवाएँ



REFERENCE TIME - 21

P

p



a parrot



a postman

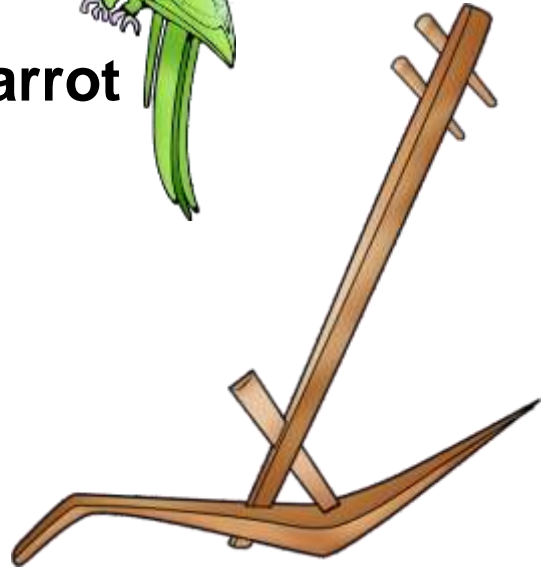

a plough



a potato

P P P

p p p

Note for the Teacher : 'P' से प्रारंभ होने वाले अन्य शब्दों के बारे में चर्चा करें एवं उनके चित्र पोर्टफोलियो में चिपकाने को कहें।

TRACING - 27

P P P

P P P

P P P

P P P

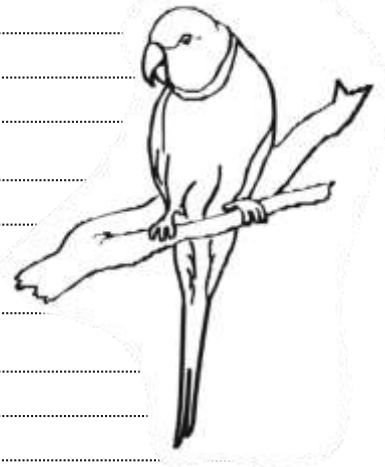

p p p

p p p

p p p

p p p



Note for the Teacher : चित्रों में रंग भरवाएँ एवं उनके अंग्रेजी नाम का अभ्यास करवाएँ



REFERENCE TIME - 22

R

r



a rat



run



a radish



a radio

R R R

r r r

Note for the Teacher : R से प्रारंभ होने वाले अन्य शब्दों के बारे में चर्चा करें एवं उनके चित्र पोर्टफोलियो में चिपकाने को कहें।

TRACING - 28

R R R

R R R

R R R

R R R

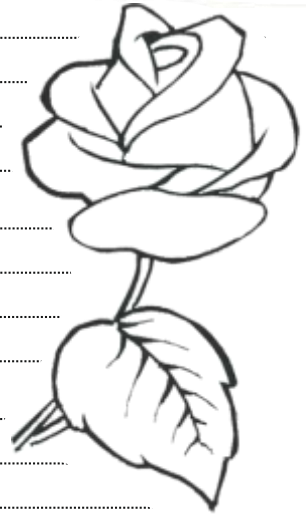

r r r

r r r

r r r

r r r



Note for the Teacher : चित्रों में रंग भरवाएँ एवं उनके अंग्रेजी नाम का अभ्यास करवाएँ



REFERENCE TIME - 23

G

g



a goat



a gardener



grapes



a girl

G G G

g g g

Note for the Teacher : 'G' से प्रारंभ होने वाले अन्य शब्दों के बारे में चर्चा करें एवं उनके चित्र पोर्टफोलियो में चिपकाने को कहें।

TRACING - 29

G G G

G G G

G G G

g g g

g g g

g g g

g g g

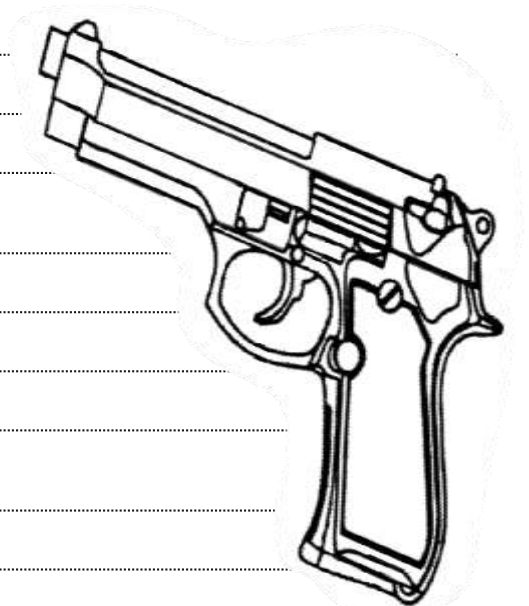

Note for the Teacher : चित्रों में रंग भरवाएँ एवं उनके अंग्रेजी नाम का अभ्यास करवाएँ



REFERENCE TIME - 24

J

j



a jeep



a joker



a jug

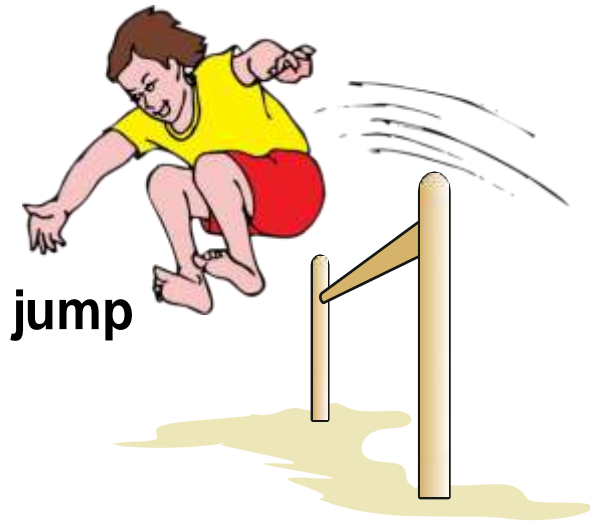

jump

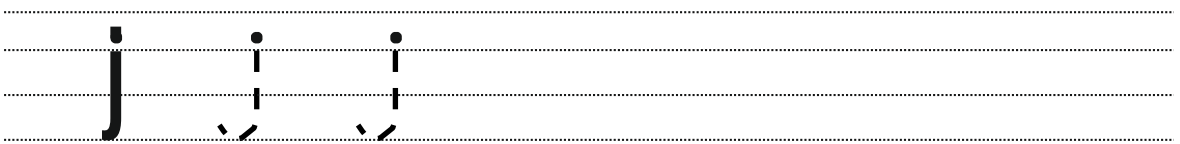
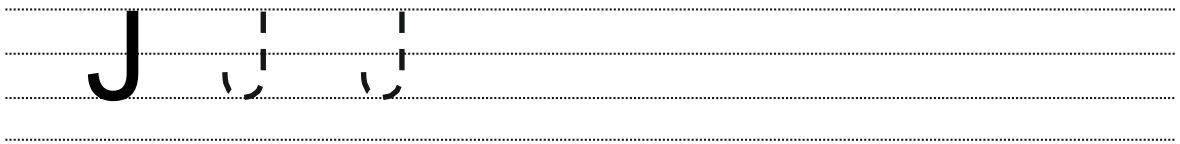

Note for the Teacher : 'J' से प्रारंभ होने वाले अन्य शब्दों के बारे में चर्चा करें एवं उनके चित्र पोर्टफोलियो में चिपकाने को कहें।

TRACING - 30

J J J

J J J

J J J

J J J

j j j

j j j

j j j

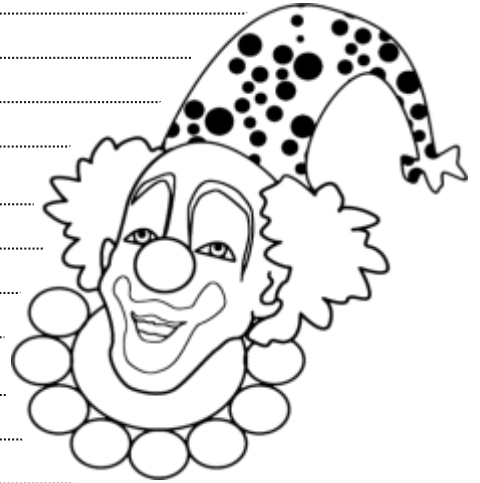

Note for the Teacher : चित्रों में रंग भरवाएँ एवं उनके अंग्रेजी नाम का अभ्यास करवाएँ



REFERENCE TIME - 25

U

u



a uniform



an umbrella



an urn

U U U

u u u

Note for the Teacher : 1. 'U' से प्रारंभ होने वाले अन्य शब्दों के बारे में चर्चा करें एवं उनके चित्र पोर्टफोलियो में चिपकाने को कहें। खाकी वर्दी (Uniform) पर बच्चों से चर्चा करें

TRACING - 31

U U U

U U U

U U U

U U

u u u

u u u

u u u

u u u

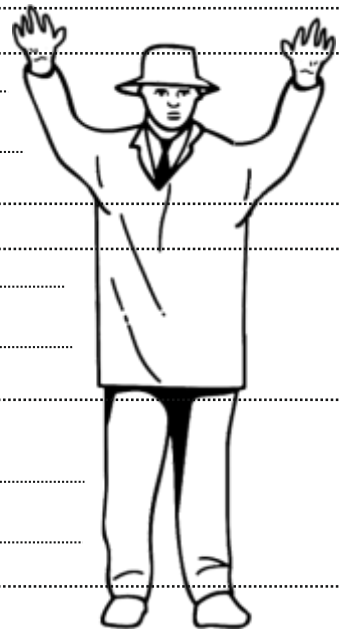

Note for the Teacher : चित्रों में रंग भरवाएँ एवं उनके अंग्रेजी नाम का अभ्यास करवाएँ



REFERENCE TIME - 26

S

s



a ship



a sparrow



a snake



a sunflower

S S S

s s s

Note for the Teacher : 'S' से प्रारंभ होने वाले अन्य शब्दों के बारे में चर्चा करें एवं उनके चित्र पोर्टफोलियो में चिपकाने को कहें।

TRACING - 62

S S S

S S S

S S S

S S S

s s s

s s s

s s s

s s s

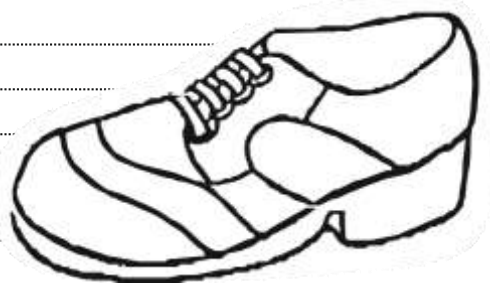
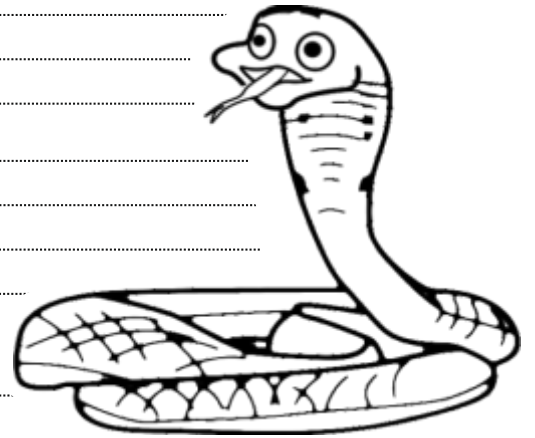

Note for the Teacher : चित्रों में रंग भरवाएँ एवं उनके अंग्रेजी नाम का अभ्यास करवाएँ



WORKSHEET - 4

Write the letters in the box given .

दिए गए अक्षरों को बॉक्स में लिखें ।

a b c d

e f g h

i j k l

m n o p

q r s t

u v w x

y z



WORKSHEET - 5

Write the name of things which you see in the picture.

चित्र में दी गई वस्तुओं का नाम लिखो।



.....

.....

.....

.....

.....

.....

.....

.....

.....

.....



WORKSHEET - 6

There are many things with Birju. Neetu asked for the things that start with 'B'. Name the things that Birju will give to Neetu.

बिरजू के पास कई चीजें हैं, नीतू ने उससे 'B' अक्षर से शुरू होने वाली चीजों को माँगा है, बिरजू जिन वस्तुओं को नीतू को देगा, उनके अँग्रेजी नाम बताओ।

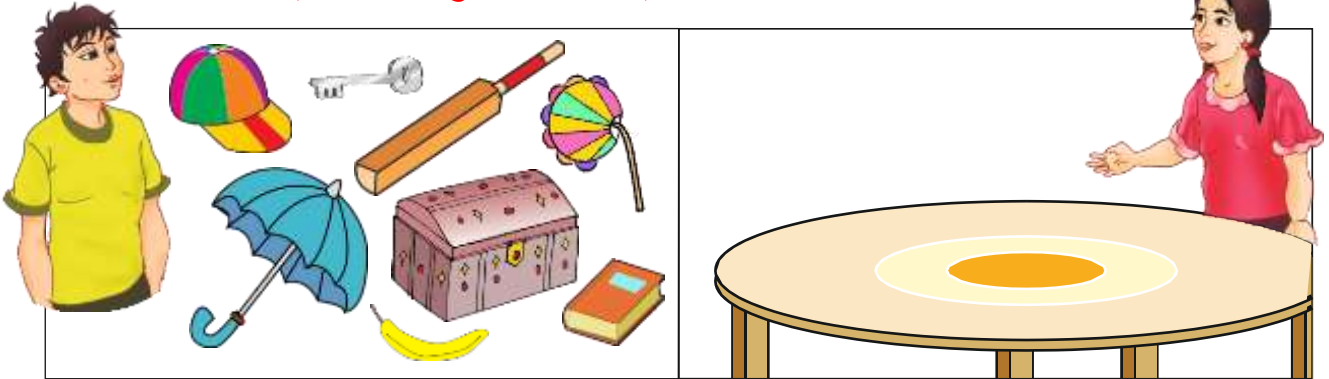

Write the names of animals.

fp=ksa esa fn, x, tkuojksa ds uke fy[kksA





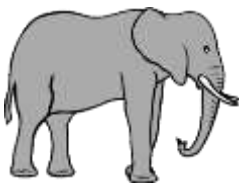













WORKSHEET - 7

Draw the pictures of fruits that you get in summer. Write their names in the blank.

गर्मियों में मिलने वाले फलों के चित्र बनाओ और अँग्रेजी में उनके नाम लिखो ।

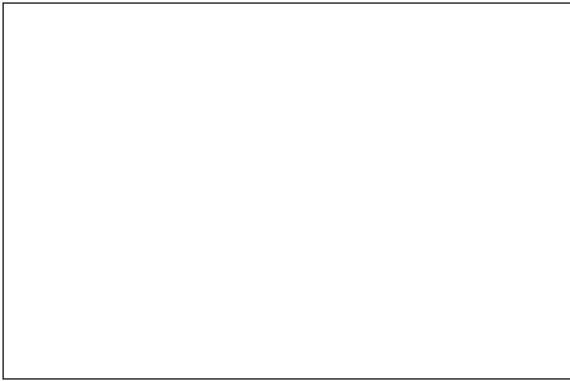

.....
.....
.....

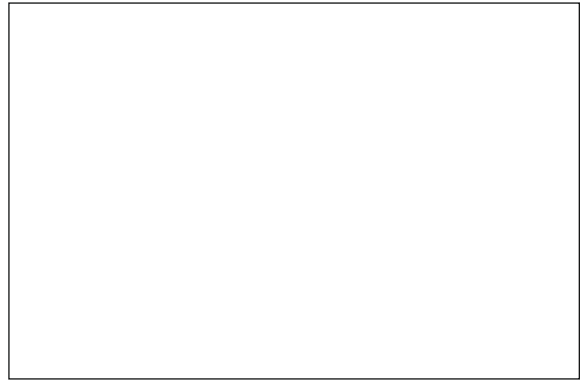

.....
.....
.....



.....
.....
.....

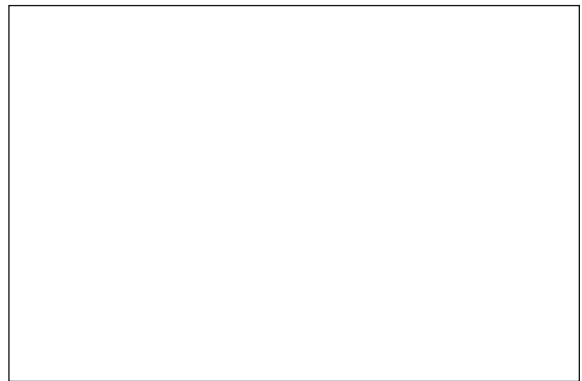











.....
.....
.....



WORKSHEET - 8

Write the names.

नाम लिखे :-







	<input type="text"/>	<input type="text"/>	
	<input type="text"/>	<input type="text"/>	
	<input type="text"/>	<input type="text"/>	
	<input type="text"/>	<input type="text"/>	
	<input type="text"/>	<input type="text"/>	

WORKSHEET - 9

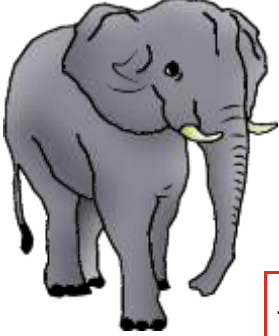
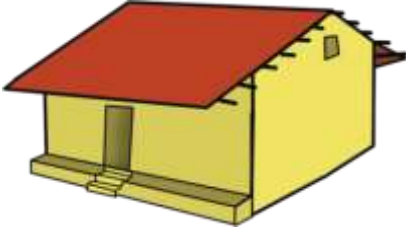
Tell the names of the pictures and write them.

चित्रों के अंग्रेजी नाम बताओ और लिखो-

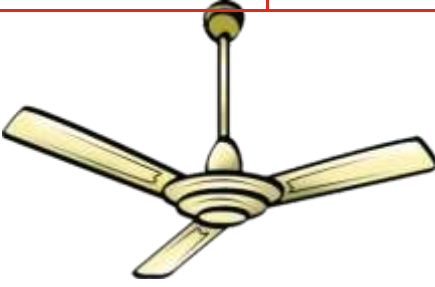





























 _____	 _____
 _____	 _____
 _____	 _____
 _____	 _____



WORKSHEET - 10

Recognise the picture, say their name match the words with the pictures.

चित्रों को पहचानो। उनके अंग्रेजी नाम बताओ। शब्दों के साथ चित्रों की जोड़ी बनाओ।

chair

jug bat

banana potato

doctor grapes

bus



WORKSHEET - 11

Recognise the pictures and complete the words.

चित्रों को पहचानो एवं शब्दों को पूर्ण करो।



p _ _ _ _



g _ _ _ _



j _ _ _



j _ _ _



r _ _



w _ _ _



s _ _ _ _



p _ _ _ _



d _ _



g _ _ _ _



p _ _ _ _



r _ _ _ _



WORKSHEET - 12

Colour the pictures and repeat after your teacher .

रंग भरो एवं दोहराओ



ball



bird



book



house



rose



balls



birds



books



houses



roses

Note for the Teacher :

1 - चित्रों में रंग भरवाएँ।

2 - वचन (Number) की अवधारणा से बच्चों को अवगत कराएँ।



WORKSHEET - 13

Draw some pictures with the letters given .

इन अक्षरों से तुम कौन से चित्र बना सकते हो-

O

F

Q

J

Recognise the letters in these pictures :-

इन चित्रों में कौन से अक्षर हैं या बनते हैं उन्हें पहचानो -

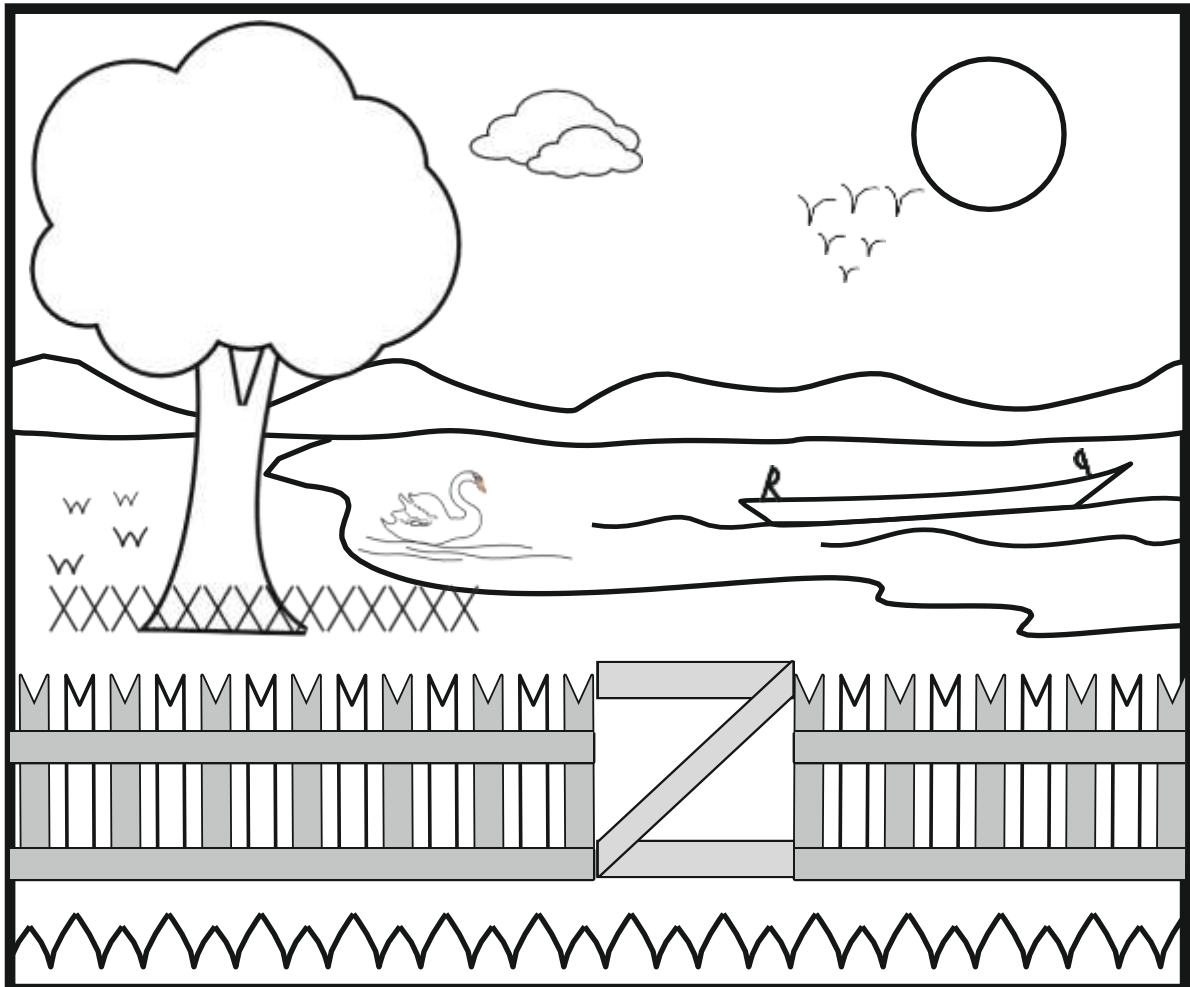



A B C D E

A B C D E

I' m in a mango tree

F G H I J

Do you want to play?

K L M N O P Q

Bring a friend or two

R S T U V

A Zebra and a Chimpanzee

W X Y Z

Play till it's time to bed

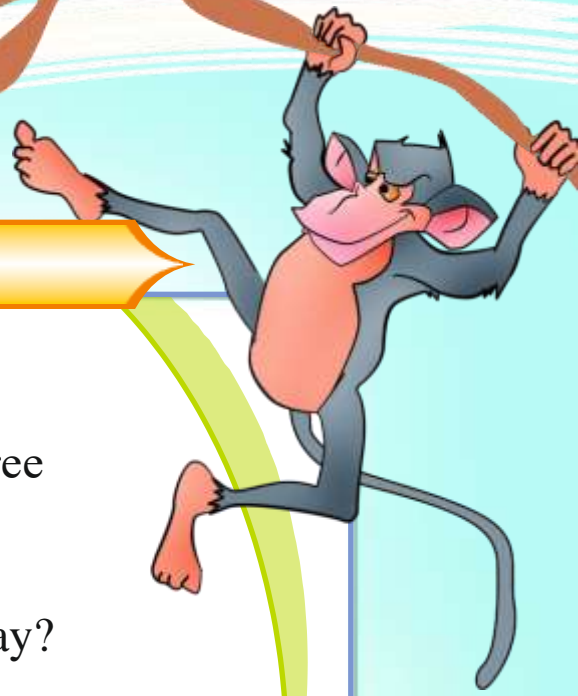

Note for the Teacher :

बच्चों को सही लय एवं हाव-भाव के साथ कविता का अभ्यास करवाएँ।



DAYS OF THE WEEK

SUNDAY

MONDAY

TUESDAY

WEDNESDAY

THURSDAY

FRIDAY

SATURDAY

There are seven days in a week.

S
P
E
A
K
I
N
G

Today is -----.

Yesterday was -----.

Tomorrow will be -----.

----- begins with an 'F'.

----- is always a holiday.

----- begins with a 'W'.

Note for the Teacher :

- 1 सप्ताह में दिनों के नाम का अभ्यास करवाएँ।
- खाली स्थानों का अभ्यास करवाएँ।
Today, Tomorrow, Yesterday का अर्थ समझाएँ।



NUMBERS

1

One

2

Two

3

Three

4

Four

5

Five

6

Six

7

Seven

8

Eight

9

Nine

10

Ten

11

Eleven

12

Twelve

13

Thirteen

14

Fourteen

15

Fifteen

16

Sixteen

17

Seventeen

18

Eighteen

19

Nineteen

20

Twenty

30

Thirty

40

Forty

50

Fifty

60

Sixty

70

Seventy

80

Eighty

90

Ninety

100

Hundred



THEY HELP US



a barber



a milkman



a potter



a carpenter



a postman





a mason



RAMU AND THE RAT

You have a stick,
But I have teeth,
Stay where you are
Or I'll bite your feet.



stick	
teeth	
feet	

Repeat after your teacher:

you - too, shoe

bite - kite, light

stick - thick, pick

feet - meet, sheet

stay - ray, they

Note for the Teacher :

- 1- सही लय एवं हाव-भाव के साथ इस कविता का अभ्यास करवाएँ।
- 2- बच्चों से पुराने अखबार या पत्रिका से चूहे का चित्र काटकर पोर्टफोलियो में चिपकाने को कहें।
- 3- समान ध्वनि वाले शब्दों का उच्चारण करवाएँ।



THE PARROT

The parrot is a pet,
The best I have met.
It can call my name,
And even play a little game.



Repeat after your teacher:

pet - set, met	name - game, tame
best - test, nest	play - clay, may
can - fan, pan	call - all, ball

Note for the Teacher :

- 1 - सही लय एवं हाव-भाव के साथ इस कविता का अभ्यास करवाएँ।
- 2 - बच्चों से पुराने अखबार या पत्रिका से तोते का चित्र काटकर अपने पोर्टफोलियो में चिपकाने को कहें।
- 3 - समान ध्वनि वाले शब्दों का उच्चारण करवाएँ।



THE BUTTERFLY

Oh, pretty butterfly,
Why can't we fly ?
Up into the sky,
Just you and I !



Repeat after your teacher:

pretty - city, kitty
just - must, rust
you - to, who
fly - sky, tie, I

Note for the Teacher :

- 1 . सही लय एवं हाव-भाव के साथ इस कविता का अभ्यास करवाएँ।
- 2 . बच्चों से तितली का चित्र श्यामपट पर बनवाएँ।
- 3 . समान ध्वनि वाले शब्दों का उच्चारण करवाएँ।



I SEE ...

I see the sun
Big, round and yellow
when I wake up.

I see the moon
Big and white
when I go to bed.



Repeat after your teacher:

sun	-	run, fun
round	-	sound, ground
yellow	-	fellow, hello
wake	-	take, make
white	-	light, right
moon	-	soon, june
when	-	hen, then

Note for the Teacher :

1. सही लय एवं हाव-भाव केसाथ इस कविता का अभ्यास करवाएँ।
2. समान ध्वनि वाले शब्दों का उच्चारण करवाएँ।
3. कविता को आगे बढ़ाने में बच्चों की मदद करें।

Ex. - I see a black board. Big black and flat. When I go to school.



THE CLOCK

Tick-tock, Tick-tock,
Goes the clock.
Day or night,
It's always right.



Repeat after your teacher:

tick	-	sick, lick
night	-	tight, right
clock	-	flock, lock
it	-	sit, bit
day	-	may, say

Note for the Teacher :

- 1- सही लय एवं हाव-भाव के साथ इस कविता का अभ्यास करवाएँ।
- 2- बच्चों से घड़ियों के चित्र एकत्र कर लाने को कहें (पुराने अखबार या पत्रिका से)। सभी चित्रों को पोर्टफोलियो पर चिपकवाएँ। गते से एक घड़ी बनाकर बच्चों को समय बताना सिखाएँ।
- 3- समान ध्वनि वाले शब्दों का उच्चारण करवाएँ।



THE CRANE

The big white crane,
Standing in the rain.

Has a small wish,
To eat a big fish.

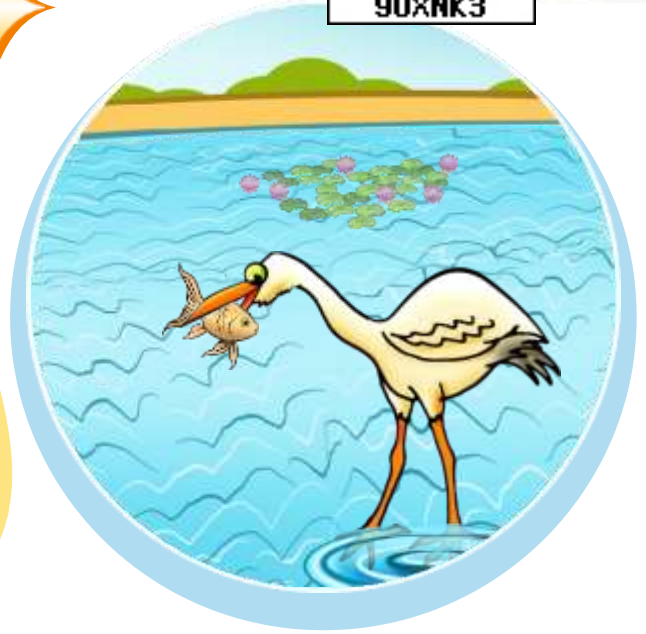

Repeat after your teacher:

big	-	pig, dig
white	-	right, kite
rain	-	train, crane
wish	-	fish, dish
small	-	ball, call
in	-	pin, tin

Note for the Teacher :

1. सही लय एवं हाव-भाव के साथ इस कविता का अभ्यास करवाएँ।
2. समान ध्वनि वाले शब्दों का उच्चारण करवाएँ।
3. ड्राईंग शीट पर मछलियों के चित्र बनवाएँ फिर उन आकृतियों को ड्राईंग शीट से काट कर अलग करवाएँ एवं उन्हें एक बड़े कागज पर चिपकाने को कहें।
4. बच्चों को बताएँ कि सारस क्या-क्या खाता है। हिन्दी कविता "बगुला भगत कहता है....." बच्चों को सुनाएँ।



OPEN THEM, SHUT THEM

Open them, shut them,

Open them, shut them.

Give a Little Clap,

Clap, Clap, Clap.

Open them, shut them,

Open them, shut them.

Fold them in your lap,

lap, lap, lap .



Repeat after your teacher:

fold - told, cold

lap - tap, clap, flap

shut - cut, hut

Note for the Teacher :

- 1 . सही लय एवं हाव-भाव के साथ इस कविता का अभ्यास करवाएँ।
- 2 . कविता के साथ Action करवाएँ।
- 3 . समान ध्वनि वाले शब्दों का उच्चारण करवाएँ।



HANDS UP

Hands up
Hands down
Hands on waist
Sit down
Stand up
Hands on the side
One, two, three, hop
One, two, three, stop
Stand still.



Repeat after your teacher:

hands	-	bands, lands	three	-	free, tree
up	-	cup, pup	sit	-	fit, bit
bend	-	send, lend	still	-	skill, till
pop	-	stop, cop	sides	-	rides, hides

Note for the Teacher :

- 1 . सही लय एवं हाव-भाव के साथ इस कविता का अभ्यास करवाएँ।
- 2 . कविता के साथ Action करवाएँ।
- 3 . समान ध्वनि वाले शब्दों का उच्चारण करवाएँ।
- 4 . इसी प्रकार के अन्य Action song / खेल सिखाएँ।
- 5 . निर्देश देने हेतु प्रयोग की जाने वाली भाषा का अभ्यास करवाएँ।



ON THE WAY TO SCHOOL



Pinky and Raja go to school everyday.

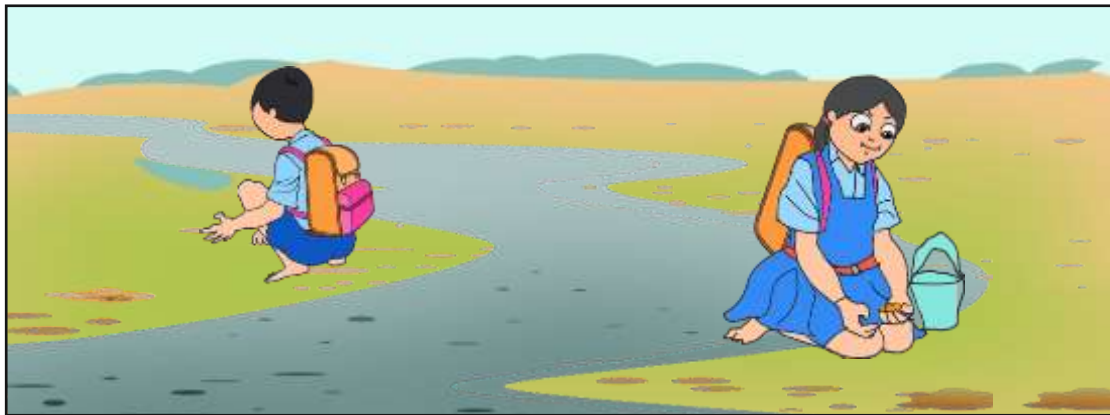

They sowed small seeds on both sides of the road.

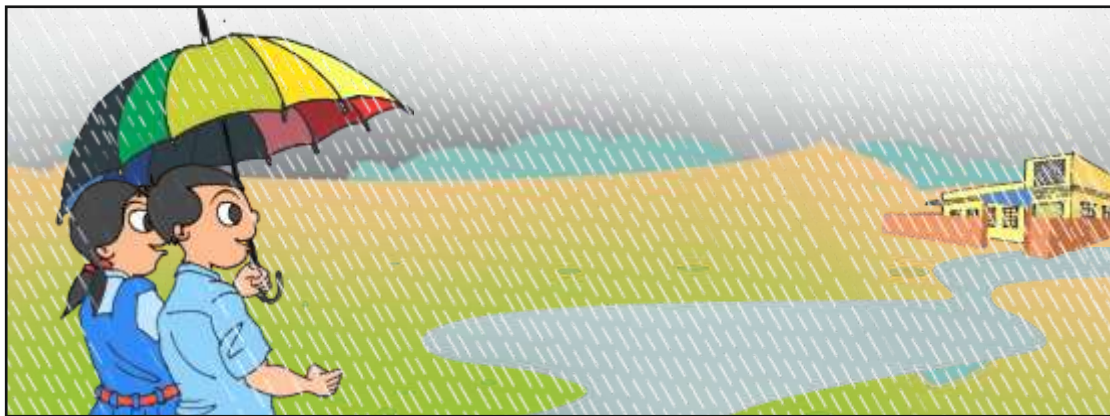

Then came the rains.



The seeds grew into small plants.



Now there are lovely flowers on the way to school!

Note for the Teacher : शिक्षक बच्चों से राय लें कि वे शाला में कौन-कौन से पेड़/पौधे लगाना चाहेंगे।

Project : बच्चों को बीज बोने/पेड़ लगाने हेतु प्रेरित करें।



Exercise

I. Fill in the blanks.

रिक्त स्थान भरो।

1. Pinky and Raja go to everyday.
2. andsowed these seeds.
3. The seeds grew into small

II. Put number in the box to show the sequence in the story.

कहानी के अनुसार सही क्रम दर्शाने के लिए अंक लिखो।

rain came	<input type="text"/>
small plants grew	<input type="text"/>
sowed seeds	<input type="text"/>
flowers grew	<input type="text"/>



BITTU SWINGS ON THE TREE



Bittu loves her mango tree.



Birds and squirrels swing on its branches. Bittu looks at them. She is sad .

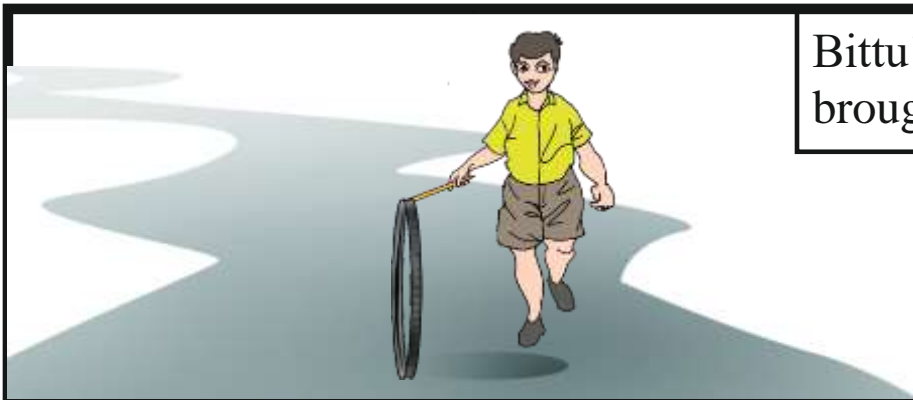

Bittu's brother Pintoo brought a tyre .

They hung it on the tree and tied it with a thick cloth .





Bittu also swings on the mango tree !



Now Bittu is happy .

Exercise

I am...



Happy



Sad

When you see the pictures in column 'A' say and write whether you will be happy or sad. Put a tick (✓) mark in column 'B'.

Column 'A' में दिए गए चित्रों को देखकर तुम happy होंगे या sad

Column 'B' में सही (✓) का चिह्न लगाकर लिखें-

A

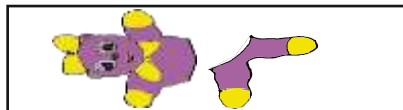

B



happy

Note for the Teacher :

- 1 - कहानी पर बच्चों से चर्चा करें।
- 2 - बच्चों से इस कहानी का रोल प्ले करवाएँ।



A RED CHILLY !

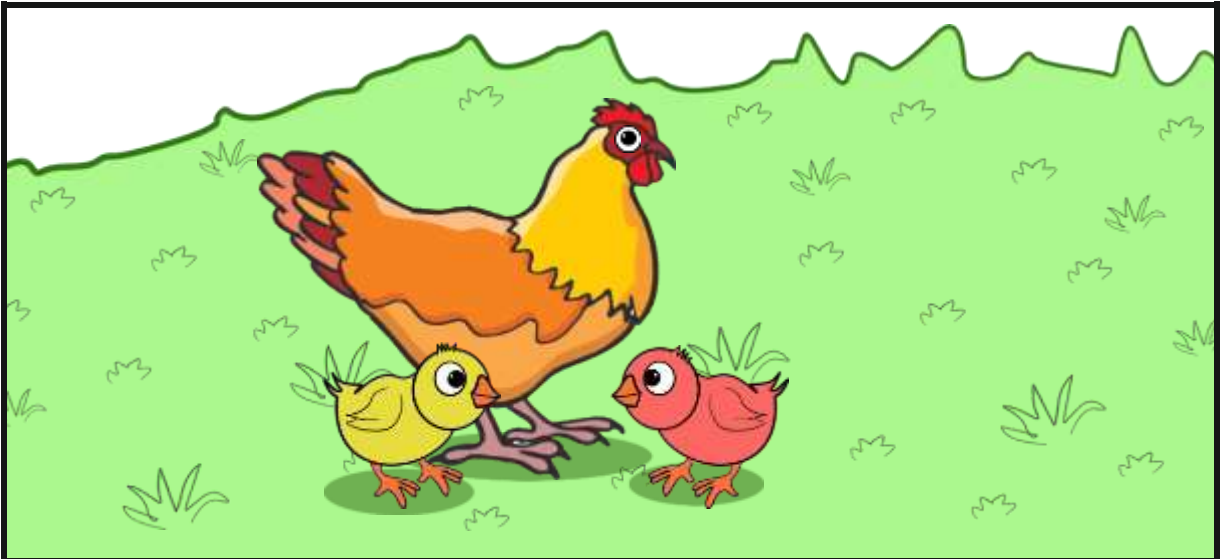

The mother hen had two chicks, Laloo & Peelu. Laloo liked red things and Peelu liked yellow.

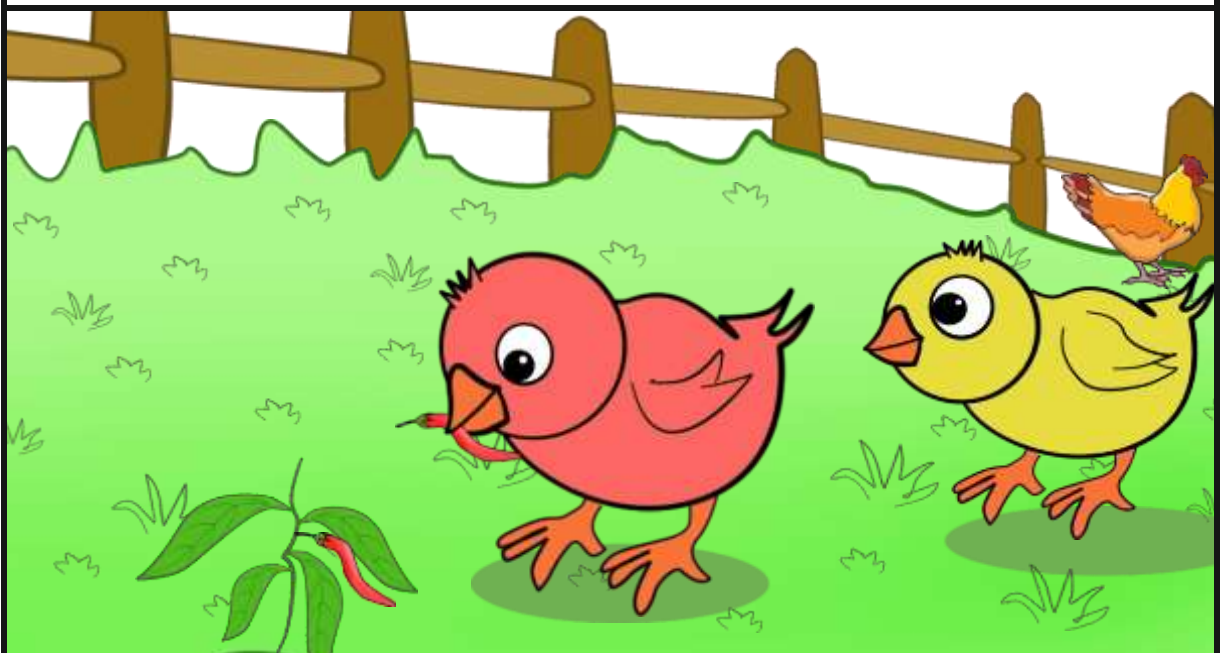

One day Laloo ate a red chilly. “Ah..... ah. ...ah., my mouth is burning”, Laloo cried.

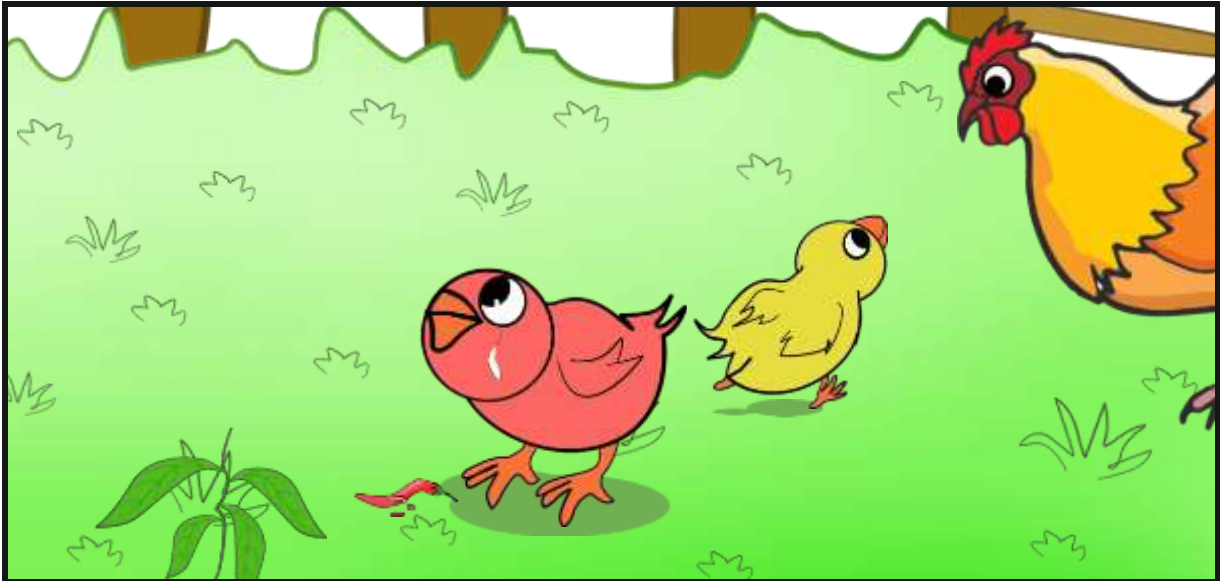

Mother hen came running.
Peelu said, "I will bring something for you."

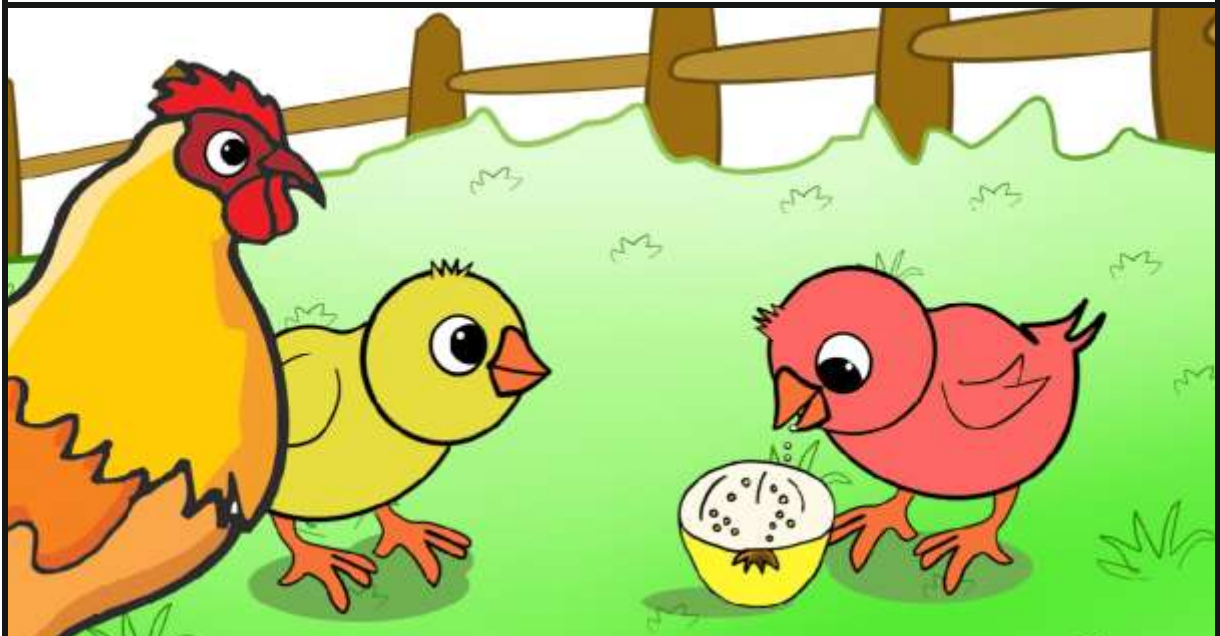

Peelu brought a ripe yellow guava. Laloo ate the guava. His mouth stopped burning.
Mother hen and Laloo said, "Thank you, Peelu."



Exercise



See the pictures and say what they are doing .

1. इन चित्रों को देखो और कहो कि ये क्या कर रहे हैं ?



2. There are two words given in each box. Say what Laloo and Peelu did with the red chilly and guava. Put a tick '✓' mark on the correct alternative.

नीचे दिए गए टेबल में प्रत्येक बॉक्स में दो शब्द दिए गए हैं। तुम्हें यह बताना है कि Laloo और Peelu ने Red chilly एवं Guava का क्या किया। जो सही है उसपर (✓) का निशान लगाओ।

		
	<div style="display: flex; justify-content: space-around;"> <div style="border: 1px solid black; padding: 5px; width: 40px; text-align: center;">eat</div> <div style="border: 1px solid black; padding: 5px; width: 40px; text-align: center;">give</div> </div>	<div style="display: flex; justify-content: space-around;"> <div style="border: 1px solid black; padding: 5px; width: 40px; text-align: center;">eat</div> <div style="border: 1px solid black; padding: 5px; width: 40px; text-align: center;">give</div> </div>
	<div style="display: flex; justify-content: space-around;"> <div style="border: 1px solid black; padding: 5px; width: 40px; text-align: center;">eat</div> <div style="border: 1px solid black; padding: 5px; width: 40px; text-align: center;">give</div> </div>	<div style="display: flex; justify-content: space-around;"> <div style="border: 1px solid black; padding: 5px; width: 40px; text-align: center;">eat</div> <div style="border: 1px solid black; padding: 5px; width: 40px; text-align: center;">give</div> </div>

3. After eating red chilly Laloo could have eaten -
Red Chilly खाने के बाद **Laloo** क्या-क्या खा सकता था ?

1 -

2 -

3 -

Note for the Teacher :

- 1 - कहानी पर बच्चों से चर्चा करें।
- 2 - बच्चों से इस कहानी का रोल प्ले करवाएँ।
- 3 - समाचार पत्र एवं पत्रिकाओं के अंग्रेजी बाल विशेष अंक की कहानियों को पढ़कर



HOW WE ARE!

Short, tall, big, small, heavy, light, hard, soft



a tall tree and a short tree

a big bag and a small bag



The bird is small
The elephant is big.



Mrs. Usha is short.
Mr. Patel is tall.

Mukesh is fat.
Aman is thin.



This table is heavy.
That chair is light.

Note for the Teacher :

चित्रों के माध्यम से दिखाए गए विरुद्धार्थी शब्दों का अभ्यास कराएँ एवं hot and cold, up and down इत्यादि शब्दों का अभ्यास कराएँ।



I. Look at the picture below choose the correct answer and rewrite the sentence :

Example : Ramu is tall.

(1) Somu is (tall/short).



Ramu



Somu

(2) Meera is (fat/thin).



Lata



Meera

(4) A rat is (big/small).

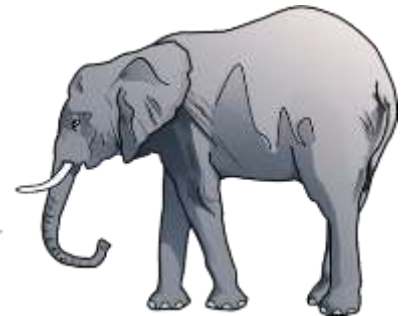

(5) An elephant is (big/ small).

Note for the Teacher :

चित्र में दर्शाए अनुसार सही शब्द पर (✓) चिन्ह लगवाएँ एवं वाक्य को सही शब्द के साथ लिखने को कहें।

II. Listen to the instructions of your teacher and draw the pictures.

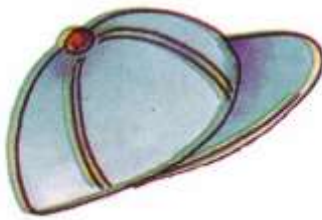

Draw a small cap
near the big cap



Draw a basket at
the bottom of the tree.

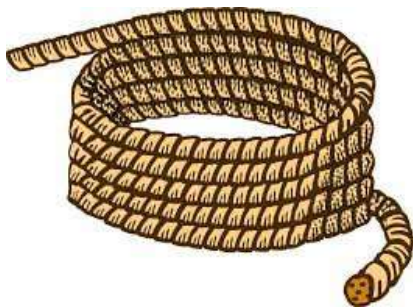

Draw a short rope
near the long rope.

RECAP : tall and short fat and thin long and short
 top and bottom big and small hot and cold
 dry and wet

Note for the Teacher :

सही विकल्प पर (✓) चिन्ह लगाने में मदद करें



Before, Between and Behind

Which animal is before the goat?

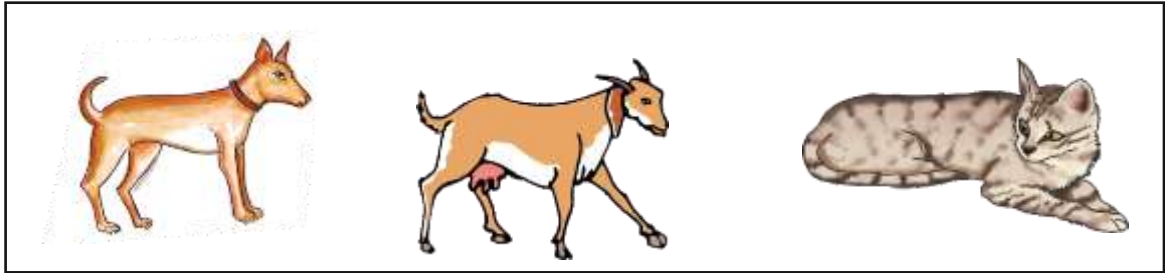

The cat is before the goat.

Which animal is behind the cow?



The horse is behind the cow.

Which animal is between the duck and the parrot?



The hen is between the duck and the parrot.

Note for the Teacher:

शीर्षक आधारित अन्य और उदाहरणों को प्रस्तुत करते हुए preposition 'before' 'between' 'behind' की अवधारणा को स्पष्ट करें।

Exercise



English - 2
Practice time

I. Look at the picture and fill in the blanks.

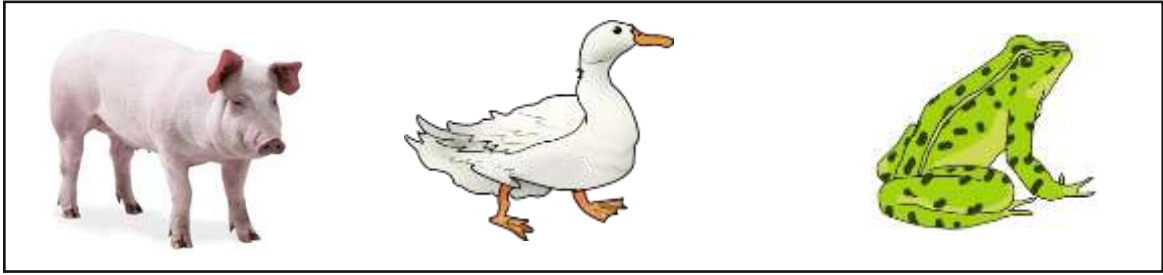

1. Which animal is behind the duck ?

The _____ is behind the duck.

2. Which animal is before the duck ?

The _____ is before the duck.

3. Which animal is between the pig and the frog ?

The _____ is the pig and the frog.

II. Describe the picture given below.



शीर्षक आधारित अन्य और उदाहरणों को प्रस्तुत करते हुए preposition 'before' 'between' 'behind' की अवधारणा को स्पष्ट करें।



THE ANIMAL WORLD

monkey, elephant, rabbit, lion, bear



Note for the Teacher : शिक्षक बच्चों को बताएँ कि बातचीत में जब किसी एक वस्तु के बारे में बताना हो और वह वस्तु पास है तो 'This' का तथा वस्तु दूर हो तो 'That' का उपयोग किया जाता है। इसी तरह कक्षा में दिखने वाली वस्तुओं को भी This या That का उपयोग कर बोलने को कहें।

Exercise



English - 2
Practice time

Look at the picture and write sentences using 'this/that'.
चित्र देखकर 'this' या 'that' का उपयोग करते हुए वाक्य लिखो।

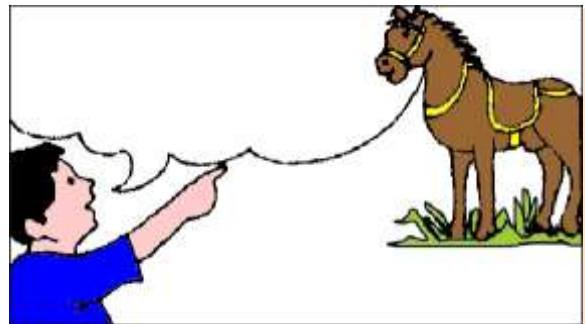
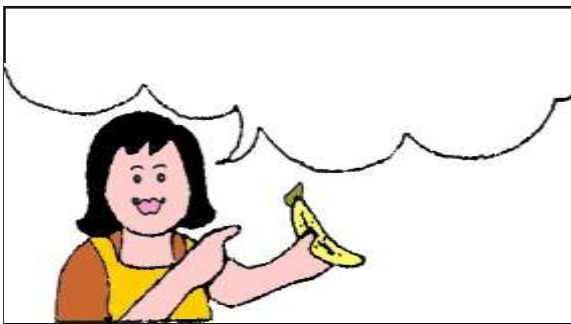
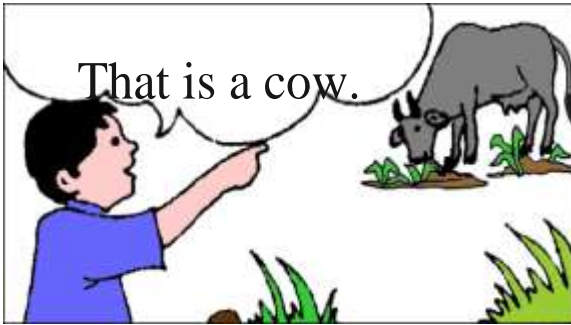
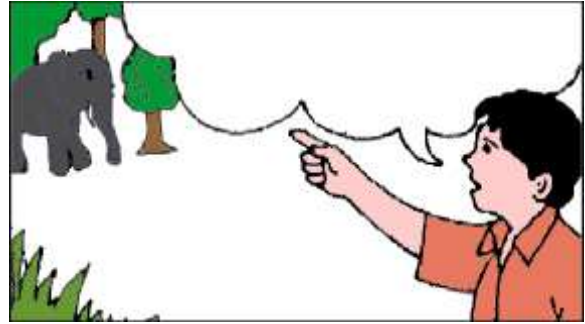

Note for the Teacher :

- * पाठ में दिये गये अभ्यास के अतिरिक्त कक्षा में अलग-अलग वस्तुएं दिखाकर बच्चों से उस वस्तु के बारे में बोलने को कहें। जैसे This is a book. That is a blackboard. This is a pencil box. That is a door. / ध्यान रखें, पास की वस्तु के लिए This तथा दूर के वस्तु के लिए That का उपयोग करवाएँ।



THE WORLD OF BIRDS

duck, parrot, crow, pigeon, peacock, owl



Note for the Teacher :

शिक्षक बच्चों को पाठ में दिए गए वाक्यों और चित्रों को दिखाते हुए बोलकर बताएं तथा बच्चों से दोहरवाएँ। उन्हें यह भी बताएं कि यदि एक से अधिक वस्तुओं का वर्णन करना हो तो पास की वस्तुओं के लिए 'These' तथा दूर की वस्तुओं के लिए "Those" शब्द का उपयोग किया जाता है।

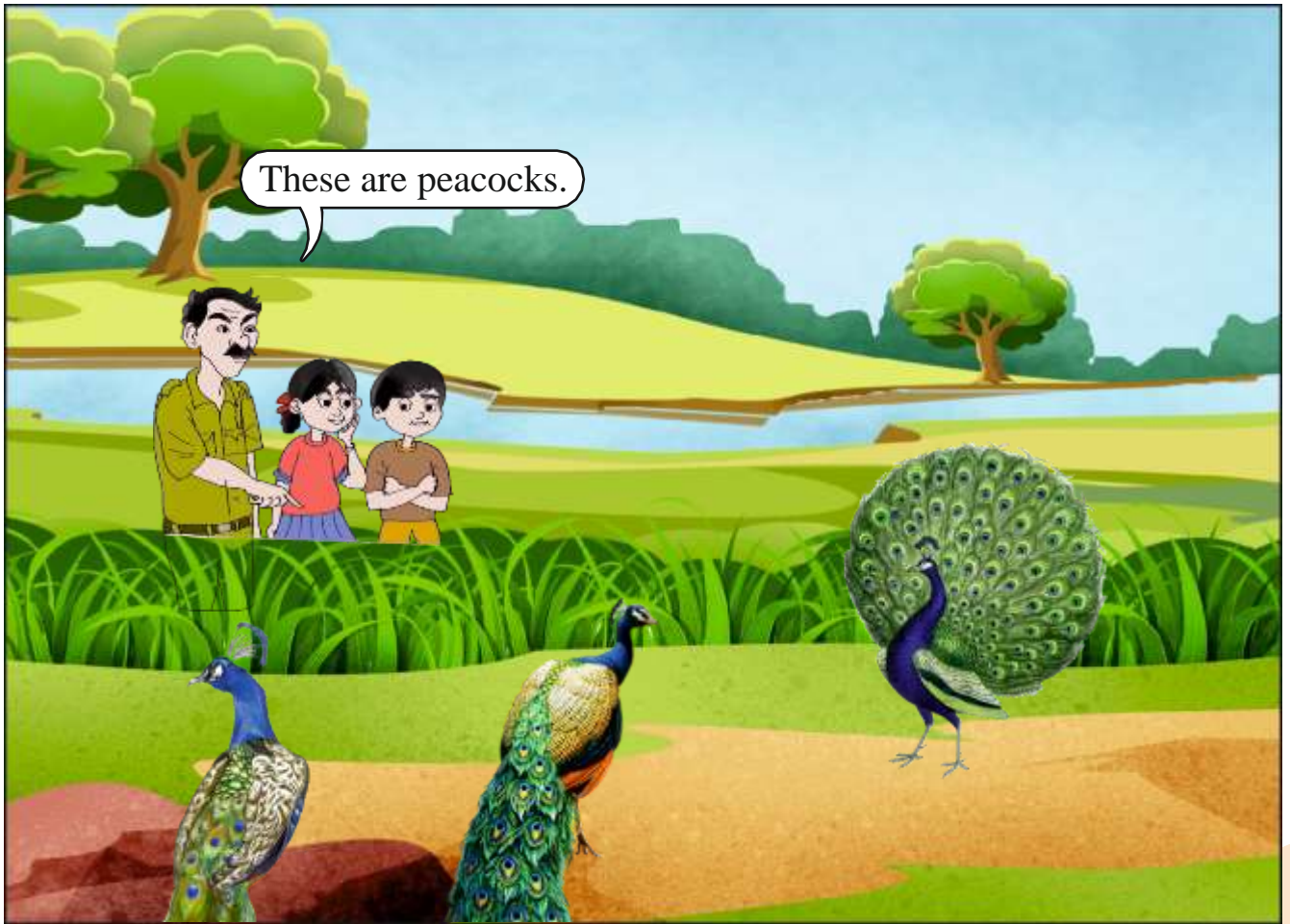

These are peacocks.











Look Kirti! those are owls.



Exercise

I. Write the sentences using 'These' or 'Those'.

'These' या 'Those' का उपयोग करते हुए वाक्य लिखो।

(I) These.....		
(ii) Those		
(iii)		
(iv).....		

II. Look at the picture and say the sentences using 'These' and 'Those'. चित्र को देखो और 'These' और 'Those' का उपयोग कर पूरा वाक्य बोलो।

Suman : Hello, Amit.

Amit : Hello Suman.

Suman : Amit, that is my school.

: my friends.

: are my teachers.

Note for the Teacher :

* अध्यापक छात्रों से पूरा वाक्य दोहराने को कहे | These एवं Those के सही उच्चारण का अभ्यास करवाएं |



a crow



crows



a parrot



parrots



a duck



ducks



a crane



cranes



a pigeon



pigeons

III. Find the names of birds in the puzzle. Some names are in plural. इस शब्द पहेली में पक्षियों के नाम ढूँढें। कुछ नाम बहुवचन में हैं।

F	D	T	C	R	A	N	E	S
P	U	P	A	R	R	O	T	S
L	C	I	G	M	C	R	O	W
O	K	G	O	P	R	Q	W	R
W	S	E	S	T	A	U	L	D
L	V	O	W	X	N	Y	Z	U
S	A	N	B	C	E	D	E	C
F	G	S	H	I	S	J	K	K

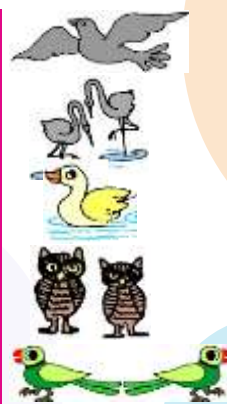

Note for the Teacher :

शिक्षक बच्चों को बताएँ कि किस तरह एक से अधिक (बहुवचन) के लिये 'S' लगाकर शब्द बनाए जा सकते हैं। अन्य शब्द भी बनवाएँ जैसे **book-books, pen-pens, pencil-pencils** आदि। अभ्यास में 3 पक्षियों के नाम ढूँढवाएँ तथा चित्र से मिलान करवाएँ।



MONI AND HER DOLL

I am Moni.
This is a doll.
This is my doll.
This is a dog.
This is my dog

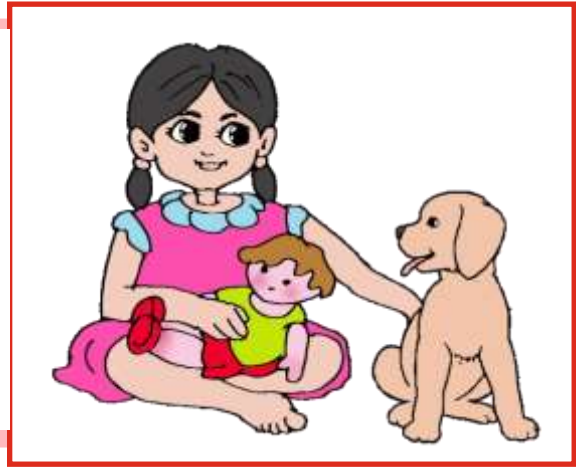

I am Sonu.
This is a cat.
This is my cat.
This is a car.
This is my car.

Look at the pictures and write the sentences using 'my'

This is my umbrella.

.....
.....
.....
.....



Note for the Teacher :

बच्चों को उनके पास अथवा कक्षा में उपलब्ध वस्तुओं के साथ उपरोक्त वाक्यों को बोलने का अभ्यास करवाएँ।



WE ARE FRIENDS



I am Sarla.
He is Mitesh.
He is my brother.
I am his sister.

I am Vikas.
She is Rupali.
She is my sister.
I am her brother.



I am Shrikant.
I am your friend.
You are my friend.
We are friends.

He is Mr. Umesh.
He is my uncle.



She is Mrs. Chitra.
She is my aunt.



Note for the Teacher :

बच्चों को दो-दो के समूह में विभाजित कर उपरोक्त वाक्यों को बोलने का अभ्यास करवाएँ एवं उन्हें अपने नोटबुक में लिखने को भी कहें।



EARLY IN THE MORNING

wash, brush, comb, walk, way, face, teeth, hair, earl

This is the way we wash our hands,
Wash our hands, wash our hands.
This is the way we wash our hands
Early in the morning.



This is the way we wash our face,
Wash our face, wash our face.
This is the way we wash our face
Early in the morning.

This is the way we brush our teeth,
Brush our teeth, brush our teeth.
This is the way we brush our teeth
Early in the morning.



This is the way we comb our hair,
Comb our hair, comb our hair.
This is the way we comb our hair
Early in the morning.

This is the way we walk to school,
Walk to school, walk to school.
This is the way we walk to school
Early in the morning.



Repeat after your teacher:

face, race, lace way, say, day walk, chalk, talk

Note for the Teacher :

बच्चों को सही लय एवं हाव-भाव के साथ इस कविता का अभ्यास करवाएँ।



MY INTRODUCTION

Let's Speak

Hello, Friends! Good Morning!

I am

I study in class II.

I live in

Mr. is my father.

He is a

Mrs. is my mother.

She is a

I have..... brothers.

I have.....sisters.

There are members in my family.

We are a happy family.



Note for the Teacher :

कक्षा के प्रत्येक बच्चे को अपना परिचय उपरोक्त वाक्यों के आधार पर देने को कहें।



CAN YOU DO THIS

- Sudha : Hello Sumit.
Sumit : Hello Sudha.
Sudha : Tell me Sumit, what is your mother tongue ?
Sumit : My mother tongue is Tamil.
Sudha : Can you speak Chhattisgarhi ?
Sumit : No, I cannot speak Chhattisgarhi.
But I can learn Chhattisgarhi.
Sudha : Can I learn Tamil ?
Sumit : Why not! You can also learn Tamil.

Read : पढ़ो-

Sudha	Sumit
I cannot speak Tamil. I can learn Tamil	I cannot speak Chhattisgarhi. I can learn Chhattisgarhi.

Now, complete the table.

Things I can do	Things I cannot do
1.	1.
2.	2.
3.	3.

देश हमारा सबसे प्यारा



राष्ट्रगान

जनगणमन—अधिनायक जय हे,
भारत—भाग्य—विधाता!
पंजाब, सिन्धु, गुजरात, मराठा,
द्राविड़, उत्कल, बंग,
विंध्य, हिमाचल, यमुना, गंगा,
उच्छल जलधि—तरंग!
तव शुभ नामे जागे,
तव शुभ आशिष माँगे,
गाहे तव जयगाथा।
जनगण मंगलदायक जय हे,
भारत—भाग्य—विधाता।
जय हे! जय हे! जय हे!
जय जय जय, जय हे!

हर देश का अपना एक विशिष्ट झंडा और राष्ट्रगान होता है। 'तिरंगा झंडा' भारतवर्ष का राष्ट्रध्वज है और 'जनगणमन' राष्ट्रगान। राष्ट्रध्वज में ऊपर की पट्टी केसरिया रंग की और नीचे की हरे रंग की होती है। बीच की सफेद पट्टी के बीचों बीच 24 शलाकाओं का नीले गहरा रंग में गोल-चक्र होता है। केसरिया रंग त्याग का, सफेद शांति का और हरा रंग प्रकृति की सुंदरता का प्रतीक है। चक्र का स्वरूप अशोक की सारनाथ-स्थित सिंहमुद्रा में अंकित चक्र की भाँति है। यह चक्र सत्य और सब धर्मों का प्रतीक है।

राष्ट्रगान की रचना गुरुदेव रवीन्द्रनाथ ठाकुर ने की थी। इसमें संपूर्ण देश के लिए मंगल-कामना है। राष्ट्रगान और राष्ट्रध्वज का सम्मान करना हमारा कर्तव्य है। जब राष्ट्रगान गाया जाय या उसकी धुन बजाई जाय अथवा राष्ट्रध्वज फहराया जाय, तब हमें सावधान की स्थिति में खड़े होकर इसे सम्मान देना चाहिए।

स्वच्छ भारत मिशन



एक कदम स्वच्छता की ओर

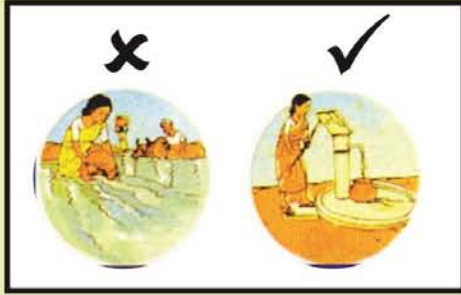

सुरक्षित पेयजल स्रोत का उपयोग करें

कूड़े कचरे का सुरक्षित निपटान करें

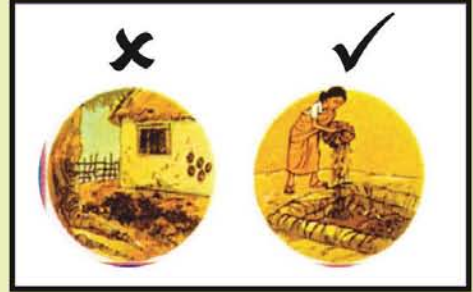

खाने के पूर्व व शौच के बाद साबुन से हाथ धोएं



खुले में शौच न करें,
शौचालय का उपयोग करें

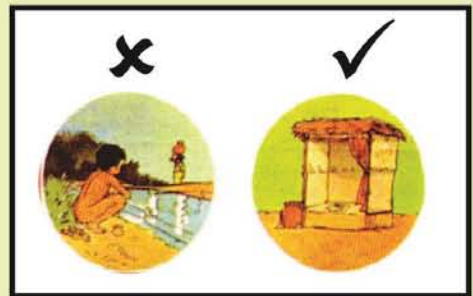

राज्य स्वच्छ भारत मिशन
छत्तीसगढ़ शासन



Chhattisgarh Text Book Corporation, Raipur